

January 23, 2013
Mitsui Chemicals, Inc.

Accident Investigation Committee Report on
the Iwakuni-Ohtake Works Explosion and Fire

Mitsui Chemicals extends heartfelt sympathy and sincerest apologies to all persons affected by the April 22, 2012 explosion and fire at Mitsui Chemicals Iwakuni-Ohtake Works.

On April 24, 2012, Mitsui Chemicals formed an [Accident Investigation Committee] comprised of members of the academia and external specialists to investigate causes of the accident to develop measures to prevent future recurrences.

This Committee met a total of eight times to determine direct and underlying causes of the accident and study measures to prevent future recurrences. The Committee has concluded its studies and issued the attached report .

Mitsui Chemicals Iwakuni-Ohtake Works
Resorcinol Plant
Accident Investigation Committee Report

January 23, 2013

Resorcinol Plant Accident Investigation Committee
Mitsui Chemicals Iwakuni-Ohtake Works

Table of Contents

1. Introduction	1
2. Overview of the Accident	
2-1. Situation in which the accident occurred	4
2-2. Damage condition	5
2-3. Determination of the origin of the explosion and fire	8
2-4. Investigation of damage to equipment	8
2-5. Second explosion	13
3. Overview of the Equipment	
3-1. Overview of each process	14
3-2. Overview of the oxidation reactor	14
4. Causes of the Accident	
4-1. Analysis of the events leading to the accident	18
4-2. Technical verification of the events leading to the accident	23
4-3. Analysis of the direct cause	30
5. Measures to Prevent Recurrence	
5-1. Development of measures for direct causes	33
5-2. Inherent measures to prevent accidents	33
5-3. Improvement of management and technology of emergency operations	41
6. Analysis of Underlying Causes and Measures to Prevent Recurrence	
6-1. Analysis of underlying causes	43
6-2. Measures to prevent recurrence for underlying causes	46
6-3. Efforts to further strengthen safety	51
7. Suggestions from the Committee Chairperson	53

1. Introduction

At 2:15am on April 22, 2012, there was an explosion and fire at the resorcinol plant at the Mitsui Chemicals Iwakuni-Ohtake Works in Waki-cho, Kuga-gun, Yamaguchi Prefecture. The fires lasted approximately 15 hours and resulted in one dead and 25 injured.

On April 24, Mitsui Chemicals formed the Accident Investigation Committee comprised of four external academics and specialists, with observers from relevant organizations, to determine the cause of the accident and develop measures to prevent recurrence.

This accident occurred at an oxidation reactor used to produce resorcinol, a substance in adhesive agents for tires. When the oxidation reactor exploded, broken pieces of the reactor were scattered in the explosion, causing the fire to spread to the cymene plant and the utilities piping rack in the same area of the Works. The glass and slate in the facilities within the plant premises were also damaged, and 999 buildings and homes in the local communities reported damage to glass windows, doors, and shutters.

At the resorcinol plant, the raw material m-Diisopropylbenzene (m-DIPB) is oxidized in the oxidation reactor with oxygen in the air, to create the resorcinol intermediate, dihydroxy peroxide (DHP). The reaction is a batch reaction, not a continuous one.

Before the accident occurred, a problem arose with the steam generating plant and all plants using steam were instructed to stop operation. In response to this, emergency shutdown (ESD) was conducted at the resorcinol plant. The interlock was activated, and the entire plant including the oxidation reactor was stopped safely. Nitrogen was introduced into the oxidation reactor to maintain replacement from air and liquid agitation, and the cooling water was switched from circulating cooling water to emergency cooling water.

The internal temperature of the oxidation reactor slowly began to drop. After about an hour, the operator decided that the cooling speed was too slow, so he released the interlock that was activated by the emergency shutdown and changed the cooling method to circulation cooling water which is normally used once the reaction is complete. This stopped the flow of nitrogen that was being used to keep the liquid agitated. At this point, the operator did not notice that the liquid agitation had stopped.

Cooling coils are installed in the bottom half of the oxidation reactor to cool the liquid, but since the liquid agitation was stopped, the DHP in the upper part of the reactor without cooling coils began to decompose and generate heat. The operator was monitoring the temperature of the reactor near the cooling coils so he did not notice that the temperature was rising in the upper part of the reactor. Later, he noticed that the internal pressure of the oxidation reactor was rising, but the temperature and pressure rose at an accelerated pace, causing the oxidation reactor to burst and resulting in the explosion and fire.

The Committee met a total of eight times to analyze and determine the direct and underlying causes and background of the accident. At the same time, Mitsui Chemicals submitted various data and analysis results to the committee, conducted experiments and simulations, and proposed measures to prevent recurrence for the causes analyzed by the Committee. The Committee discussed and confirmed each of these items, determined the direct and underlying causes and also confirmed and approved of the measures to prevent recurrence proposed by Mitsui Chemicals. This report contains a summary of the results the Committee obtained.

Accident Investigation Committee Chairperson and Members

Chairperson	Dr. Terushige Ogawa	Emeritus Professor, Yokohama National University Executive Director, Research Institute for Safety Engineering
Members	Dr. Kazuhiko Suzuki	Professor, Okayama University Graduate School of Natural Science and Technology
	Mr. Jun Nakamura	Director, Research Institute for Safety Engineering
	Dr. Masayoshi Nakamura	Professor, Tokyo University of Agriculture and Technology, The Graduate School of Technology Management

Observers

High Pressure Gas Safety Office, Industrial Safety Division, Commerce, Distribution and Industrial Safety Policy Group, Ministry of Economy, Trade and Industry

Chugoku Shikoku Industrial Safety and Inspection Department, Ministry of Economy, Trade and Industry

Disaster Prevention & Crisis Management Division, General Affairs Department, Yamaguchi Prefecture

District Firefighters, Iwakuni Fire Department

High Pressure Gas Safety Institute of Japan

Committee meeting dates and main topics of discussion

No.	Date	Main topics of discussion
1	May 1, 2012	<ul style="list-style-type: none">▪ Appointed Emeritus Professor Ogawa of Yokohama National University as the chairperson of the Committee▪ Overview of the accident, confirmed accident site
2	May 27, 2012	<ul style="list-style-type: none">▪ Events leading up to the accident
3	June 12, 2012	<ul style="list-style-type: none">▪ Events leading up to the accident, direct cause of the accident
4	July 5, 2012	<ul style="list-style-type: none">▪ Direct cause of the accident
5	July 26, 2012	<ul style="list-style-type: none">▪ Direct cause of the accident and measures to prevent recurrence
6	August 15, 2012	<ul style="list-style-type: none">▪ Determine direct cause of the accident▪ Measures to prevent recurrence of the direct cause▪ Underlying causes of the accident and measures to prevent recurrence
7	October 26, 2012	<ul style="list-style-type: none">▪ Analysis of underlying causes of the accident▪ Measures to prevent recurrence of underlying causes
8	December 18, 2012	<ul style="list-style-type: none">▪ Analysis of underlying causes of the accident▪ Measures to prevent recurrence of underlying causes

2. Overview of the Accident

2-1. Situation in which the accident occurred

(1) Location

Resorcinol Plant at the Mitsui Chemicals Iwakuni-Ohtake Works
6-1-2 Waki, Waki-cho, Kuga-gun, Yamaguchi

(Refer to Fig. 2-1)

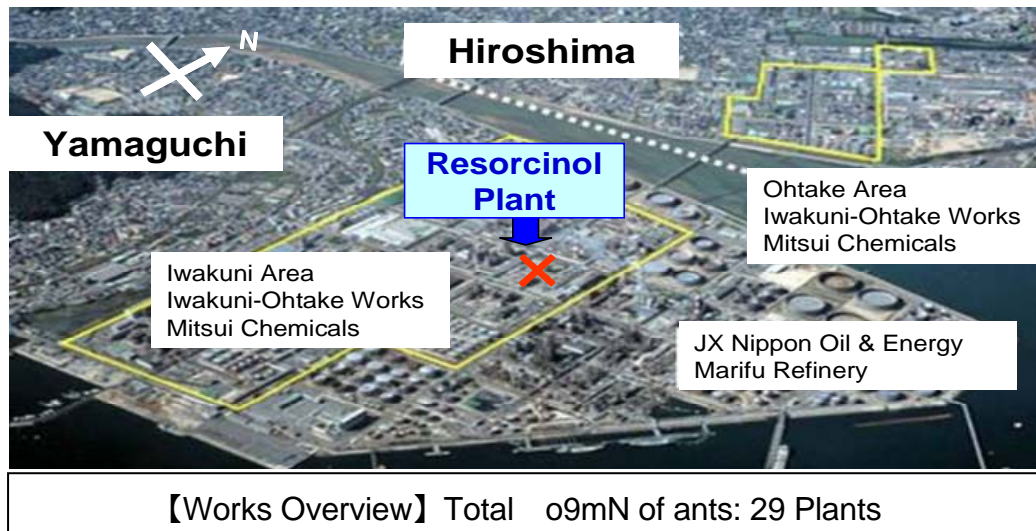

Figure 2-1 Mitsui Chemicals Iwakuni-Ohtake Works

(2) Date and Time of Accident

April 22, 2012 2:15am

(3) Timeline after Accident

April 22

- 2:15am Explosion and fire occurred at the resorcinol plant
- 2:20am The fire department was notified
Three local headquarters were established
(Command HQ, Response HQ, Administrative HQ)
Fire fighting activities were started immediately
- 8:05am Second explosion occurred at the resorcinol plant
- 5:15pm The Iwakuni Fire Department announced that the fire was under control.

April 23

- 2:31pm The Iwakuni Fire Department announced that the fire was extinguished.

2-2. Damage condition

2-2-1. Casualties and effect on surrounding area

(1) Casualties 1 dead, 25 injured

External areas

- Residents of local communities: 14 injured
- Employees of subcontractors at JX Nippon Oil & Energy Marifu Refinery: 2 injured

Within premises

- Employees: 1 dead, 7 injured (2 seriously injured)
- Employees of subcontractors: 2 injured

(2) Physical Damage

External areas

- Damage to buildings/homes: 999
- Partial damage to facilities of neighboring companies

Within premises

- Severe damage to resorcinol production plant around the oxidation reactor
- The cymene plant and utilities piping rack were damaged and burnt from the explosive wind and flying objects,
- 15 nearby plants were also damaged from the explosive wind and flying objects

2-2-2. Damage to equipment within the premises

(1) Situation at each plant

Two plants within the premises, resorcinol and cymene, were damaged by the explosion and fire. (The fire spread to the utilities piping rack due to flying debris from the resorcinol oxidation reactor.) Additionally, there were 15 plants in the Iwakuni area that reported broken glass and slate. There was also one plant in the Ohtake area where there was no damage to the equipment but the building was damaged. The remaining 11 plants in the Ohtake area were not damaged. The following is an outline of the damage at all 29 plants.

- a. Damage to equipment: 2 plants (Iwakuni area, resorcinol and cymene plants)
- b. Extensive damage to glass, slate, etc.: 15 plants
- c. Damage to some glass, slate, etc.: 1 plant (no damage to equipment)

d. No damage: 11 plants

(2) Area of damage

Damage to equipment and pipes were found in a 300m radius around the resorcinol plant. (Refer to Fig. 2-2)

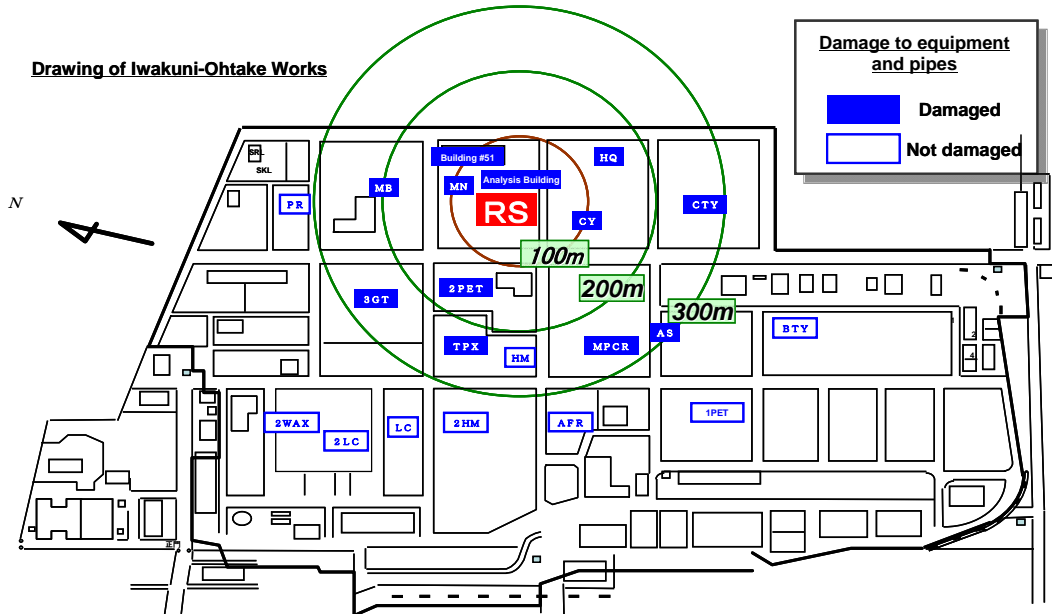

Figure 2-2 Damage within plant premises

(3) Damage to area surrounding the resorcinol plant

Fig. 2-3 shows an enlargement of the location where the fire occurred. More than half of the resorcinol plant was destroyed. At the cymene plant and the utilities piping rack, large broken pieces of the resorcinol oxidation reactor were discovered where the fire started, and there was damage from the impact of the flying debris.

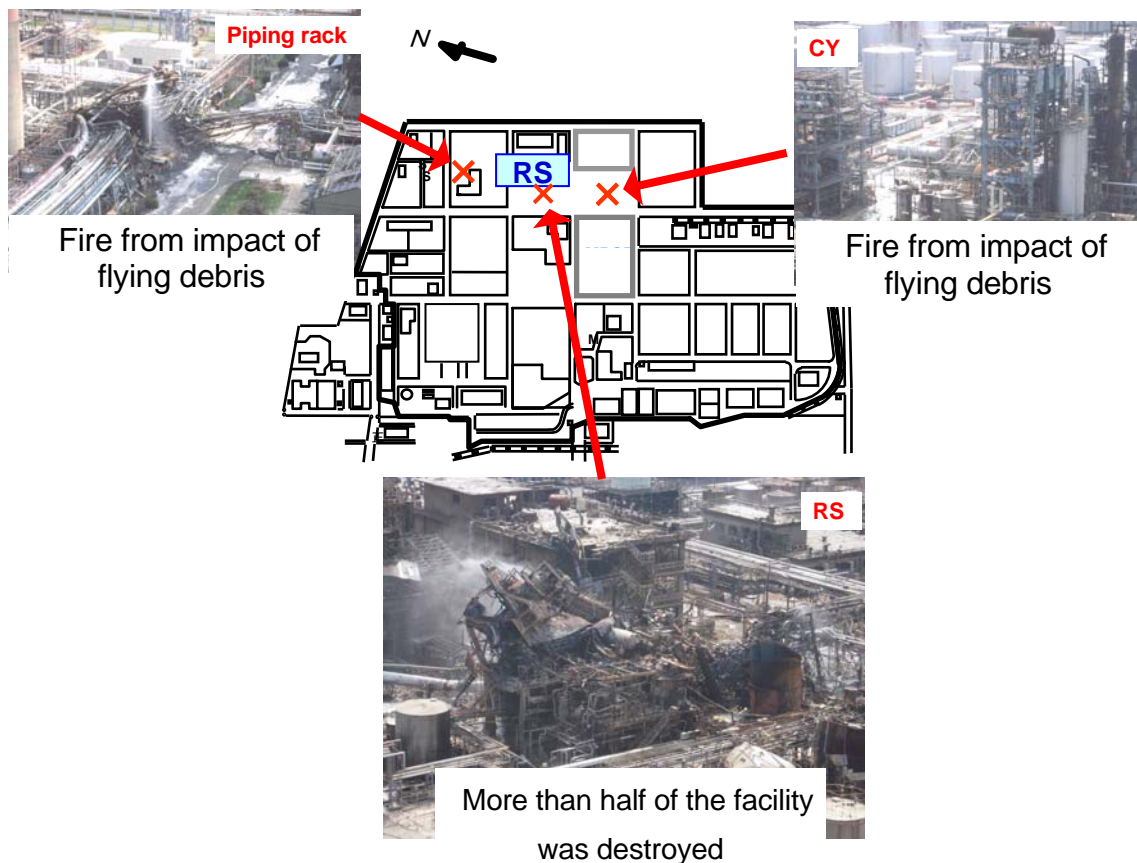

Figure 2-3 Damage to area surrounding the resorcinol plant

(4) Scattering of the oxidation reactor

The upper part of the oxidation reactor had broken into pieces and was scattered in the explosion, leaving only the skirt and the lower part of the main body (Fig. 2-4). The scattered pieces were distributed to the north (Hiroshima side) and south (Iwakuni side) of the location where the oxidation reactor was installed. The contents of the reactor were scattered to the east and west.

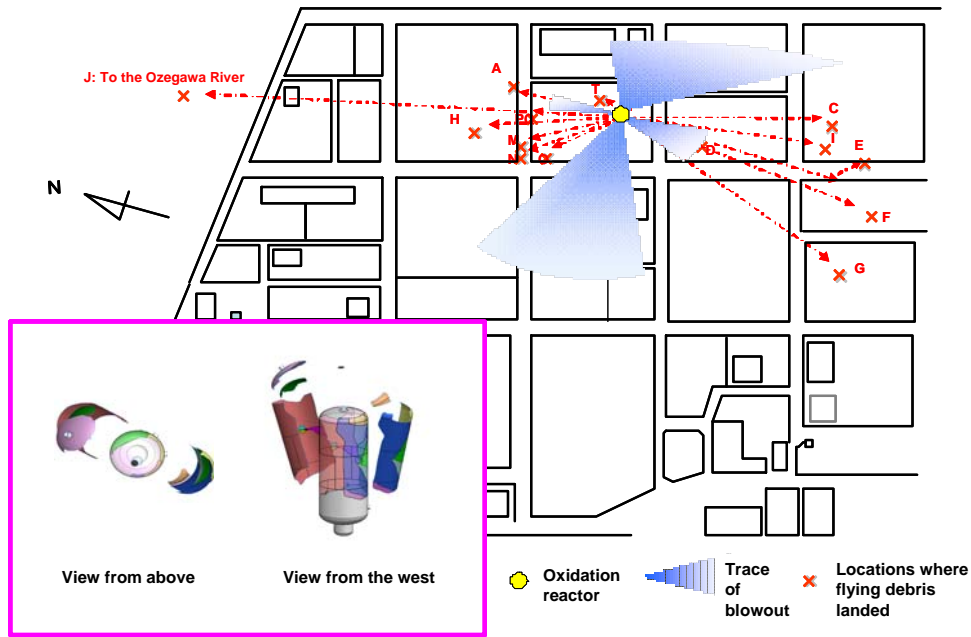

Figure 2-4 Scattering of the Oxidation Reactor

2-3. Determination of origin of the explosion and fire

It was determined that the fires at the cymene plant and the utilities piping rack were caused by debris that flew from the resorcinol plant.

An abnormal rise in temperature in the upper liquid phase in the resorcinol oxidation reactor was detected approximately an hour and a half before the explosion and fire occurred and at 2:14:55, the pressure inside the reactor exceeded the design pressure of 0.8 MPaG. This is congruent with the timing of the explosion and fire. Based on these facts, it was determined that the explosion and fire originated from the oxidation reactor at the resorcinol plant.

2-4. Investigation of damage to equipment

The pieces of oxidation reactor were collected and restored to make an estimation of plastic deformation immediately before the reactor ruptured. The fracture morphology and soundness of the material were confirmed in a destructive test. Then, methods such as FEM (finite element method) were used to make an estimation of the internal pressure that led to the rupture.

Figure 2-5 shows the estimated crack initiation and crack paths based on a visual observation of the fracture surface. It was estimated that the initiation was at the manhole which was a discontinuous part of the structure located near the 120° radius direction and at the insulation rib located near the 270° radius direction.

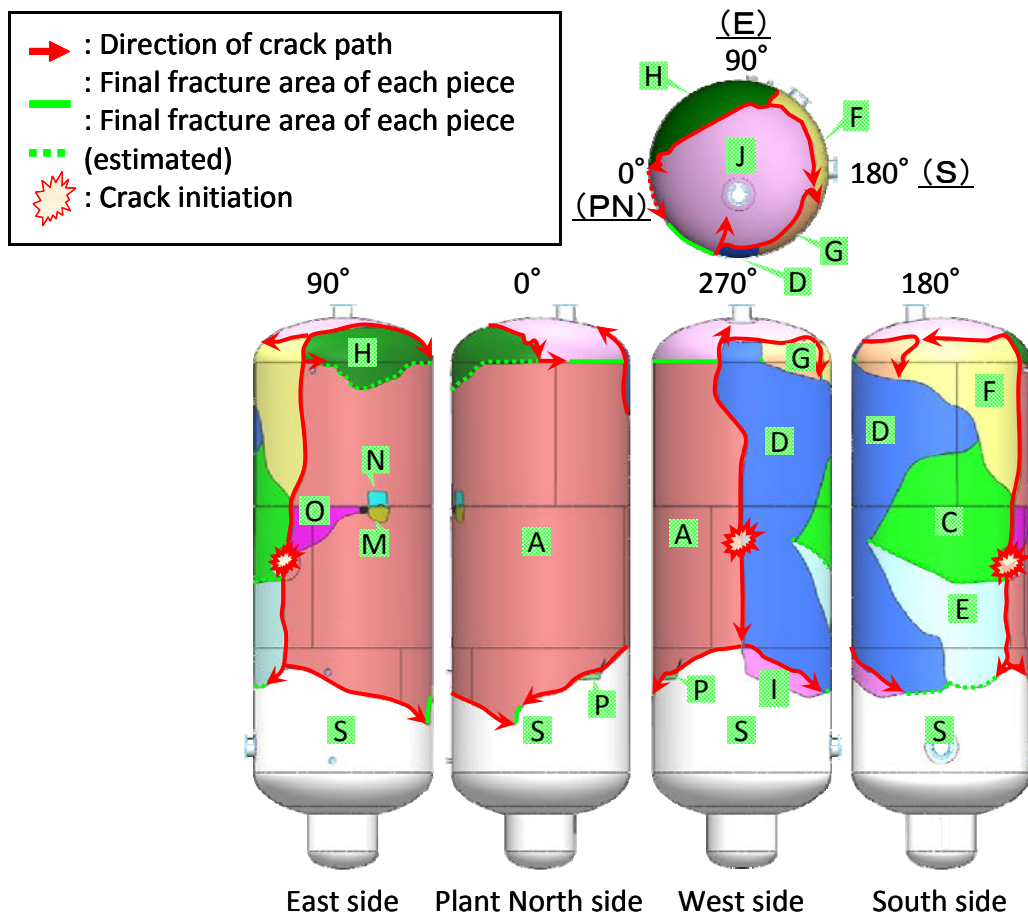

Figure 2-5 Crack initiation and crack paths

The size measurements showed that the circumference and longitudinal length of the reactor had grown and the thickness was reduced on all of the fracture surfaces.

Reduction in thickness and elongation of the microstructure from plastic deformation due to the rise in internal pressure were observed and dimples, a characteristic feature of ductile ruptures, were confirmed on all of the fracture surfaces of the initiation, crack paths and final fractured parts.

Figure 2-6 shows the cross section of the fracture surface of the reactor near the manhole that is thought to be the initiation point on the 120° radius direction (Piece C) and Figure 2-7 shows the dimple fracture surface observed on the same piece in Figure 2-6.

Additionally, after confirming texture observation, chemical component analysis and mechanical strength of the fractured material, it was determined that the properties of the material met the JIS standards and the inspection certificate requirements and no abnormalities were found in the material.

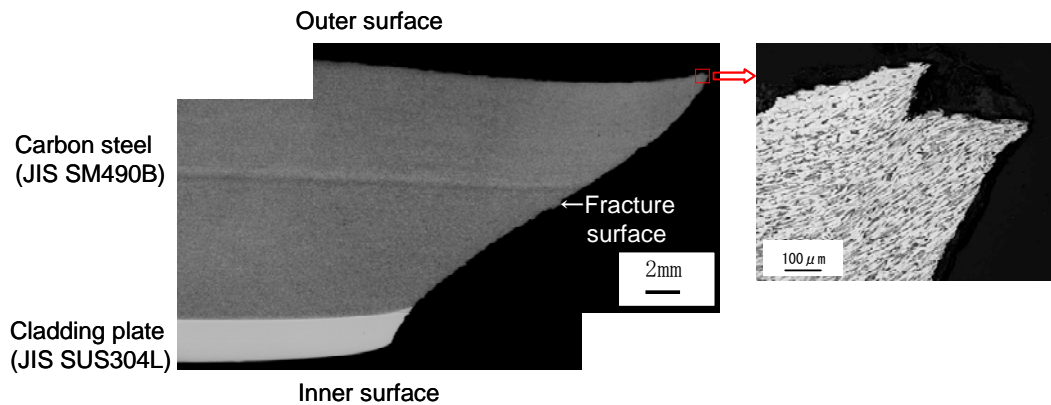

Figure 2-6 Observation of texture of fracture surface

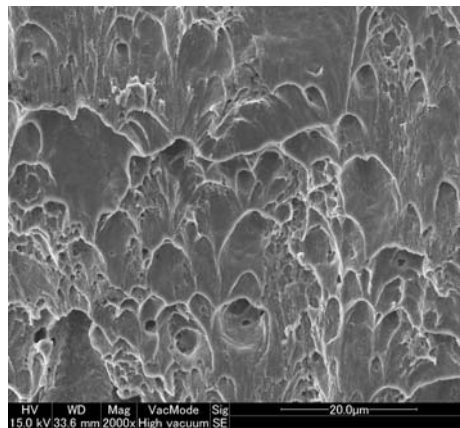

Figure 2-7 Dimple fracture surface (Carbon steel part)

Next, in order to determine the internal pressure that could rupture the oxidation reactor, FEM was used to conduct elasto-plastic analysis. The results of the analysis showed that at the base of the manhole on the upper part of the reactor near the 120° point, once the internal pressure of the oxidation reactor reaches 6.5 MPa, the stress placed on the material (tensile stress) exceeds the fracture strength of 304SS, the manhole material, and the reactor will rupture. Additionally, from the tensile stress of the manhole bolt (SS400) at the top of the tank which was found broken, it was estimated that the internal pressure of the oxidation reactor was approximately 8.06 MPa when it ruptured.

From these results, it was estimated that the pressure inside the oxidation reactor when it ruptured was 8 MPa or higher, significantly higher than the design pressure of 0.8 MPaG. It is assumed that the reactor could not withstand the pressure and ruptured (unstable ductile fracture).

2-5. Second explosion

The situation leading to the second explosion was analyzed based on video footage taken by MCI. The following was determined from the footage.

- a. After the first explosion, there were small fires around the oxidation reactor.
- b. At around 7:49, the oxidation reactor began releasing a white steam-like gas.
- c. At around 8:05, large quantities of steam-like gas burst out of the reactor.
- d. Approximately 30 seconds later, the fire spread from the oxidation reactor and an explosive fire was ignited.

Based on these observations, it is thought that after the first explosion, the oxidation reactor was not cooled sufficiently and since there continued to be small fires in the surrounding area, the reactor was heated. The heating caused the temperature of the hydroperoxide (HPO) remaining at the bottom of the reactor to rise and accelerated self-decomposition causing large quantities of flammable gas to burst out. The flammable gas and the residual liquid (mist) in the reactor were scattered and ignited to create a fire ball as shown in Figure 2-8.

After the first explosion, the people onsite responded appropriately to the situation and managed it properly and as a result there were no further casualties from the second explosion and a secondary disaster was prevented.

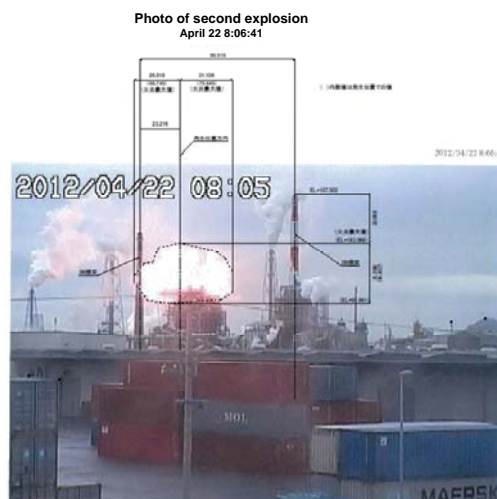

Figure 2-8 Image of the second explosion

3. Overview of the Equipment

3-1. Overview of each process (Figure 3-1)

At the resorcinol plant, m-Diisopropylbenzene (m-DIPB) was oxidized with air to create the intermediate, Dihydroxy peroxide (DHP), and the acid catalyst cleavage reaction of the DHP was used to produce resorcinol.

The aimed product of the oxidation process was DHP but the hydroperoxide (HPO, a collective name for the peroxides generated) that was actually generated was a mixture that contains by-products such as hydroxy hydroperoxide (HHP). HHP was collected as DHP at the next process, the reoxidation process. The oxidation process is a batch reaction and the processes, from reoxidation and onwards, are continuous reactions, and an intermediate tank was used to connect the two.

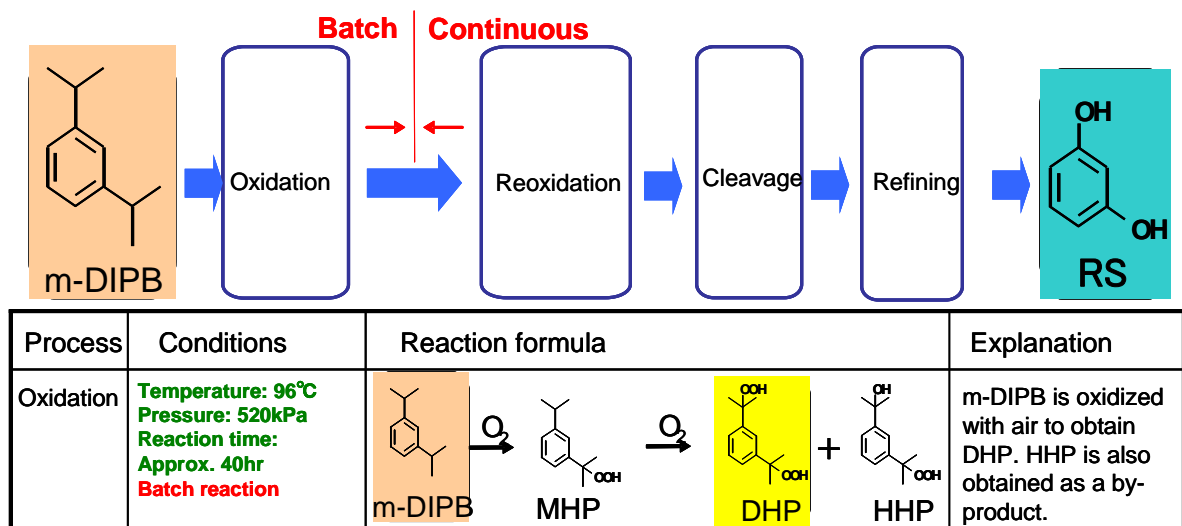

Figure 3-1 Resorcinol plant block flow and reaction formula

3-2. Overview of the Oxidation Reactor

(1) Equipment specifications

Figure 3-2 shows the specifications of the oxidation reactor.

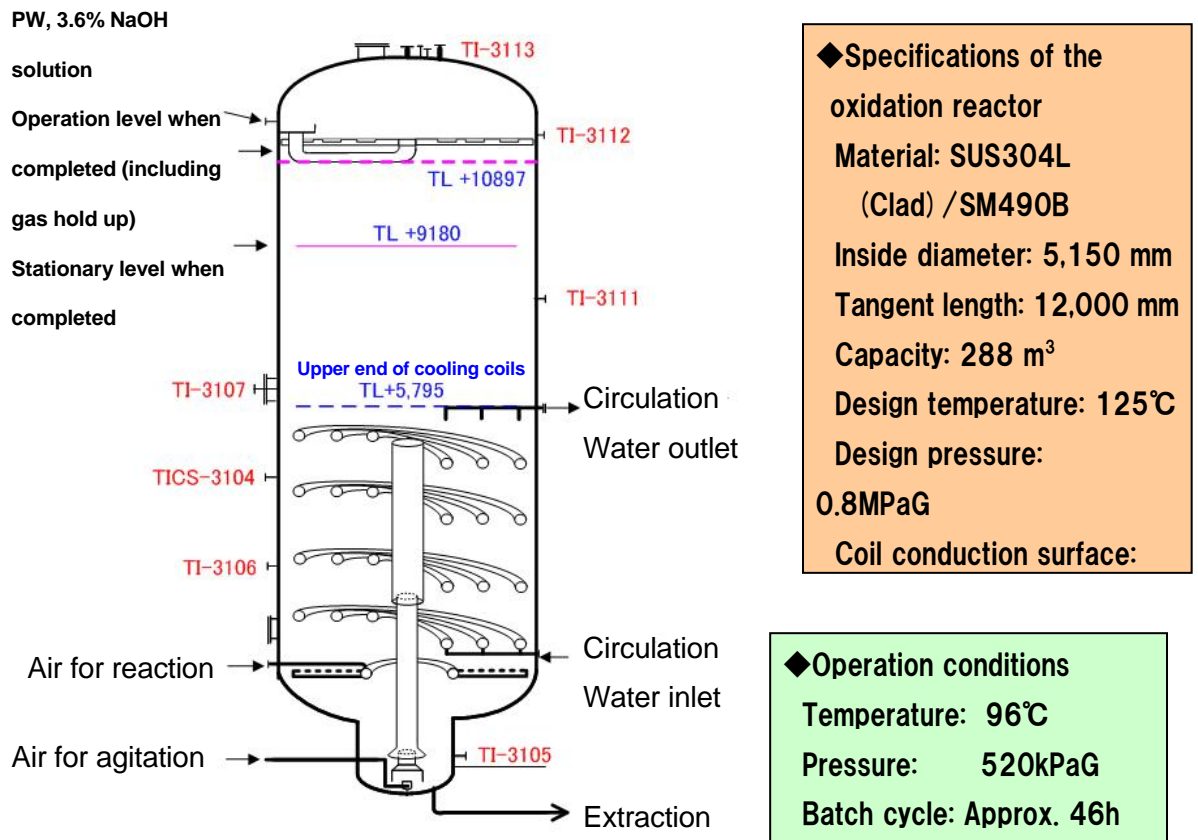

Figure 3-2 Specifications of the oxidation reactor

The reaction temperature is controlled using the temperature of the circulating water at the inlet to the cooling coil to adjust the thermometer TICS-3104 to the target temperature.

The position of each thermometer can be categorized into three sections as shown below. The three sections are the gas phase, upper liquid phase (liquid phase above the cooling coil), and lower liquid phase (liquid phase where the cooling coils were installed).

- Thermometers in the gas phase TI-3113, TI-3112
- Thermometers in the upper liquid phase TI-3111, TI-3107
- Thermometers in the lower liquid phase TICS-3104, TI-3106, TI-3105

(2) Operation conditions

The raw materials for one batch, m-DIPB, pure water (PW) and 3.6% NaOH water solution are prepared. The reaction time is approximately 40 hours and the batch cycle including preparation, cooling and extraction is approximately 46 hours.

The operation pressure during reaction is 520 kPaG and the operation temperature is controlled at 96°C. With this operation temperature and pressure, the explosive range of m-DIPB can be avoided at all times.

The air supplied to the reactor is used for both reaction and agitation. A steady volume of air is supplied for both reaction and agitation during reaction. The reaction air is supplied as tiny bubbles by passing it through the sparger. The air for agitation is supplied from the bottom part of the draft tube installed at the center of the reactor, and the entire liquid phase is agitated through air lift agitation. Overall, the center of the reactor has an upward flow and the area near the reactor walls has a downward flow. Figure 3-3 shows the agitation condition of the oxidation reactor.

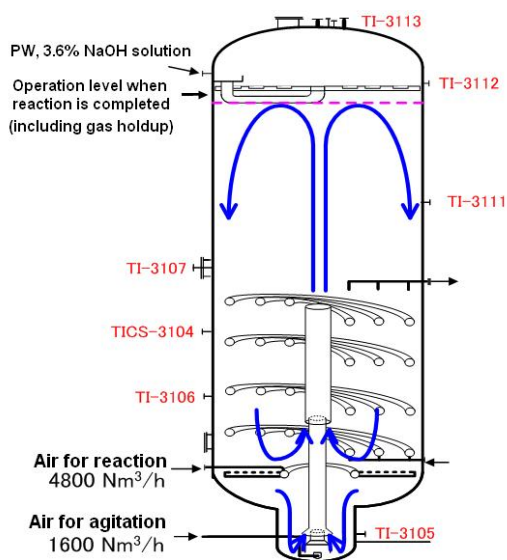

Figure 3-3 Image of the agitation in the oxidation reactor

(3) Temporal change in the composition of the reaction liquid (Figure 3-4)

Oxidation is a batch reaction, and so the composition changes with time. The raw material m-DIPB becomes MHP, and DHP (aimed product) is generated as the reaction progresses. The reaction is completed when the yield reaches its maximum point at 40 hours.

As this reaction progresses, organic acids and methanol are generated. In order to adjust the pH and viscosity, 3.6% NaOH water solution and pure water is supplied part way through the reaction.

T-HPO (total hydroperoxide concentration) is used as a measure of the progression of the reaction. This is a hydroperoxide concentration that is converted to MHP, and since DHP has two R-OOH radicals in the same molecule, when converted to MHP, the figure is doubled. When the reaction is completed, the T-HPO concentration is approximately 135%.

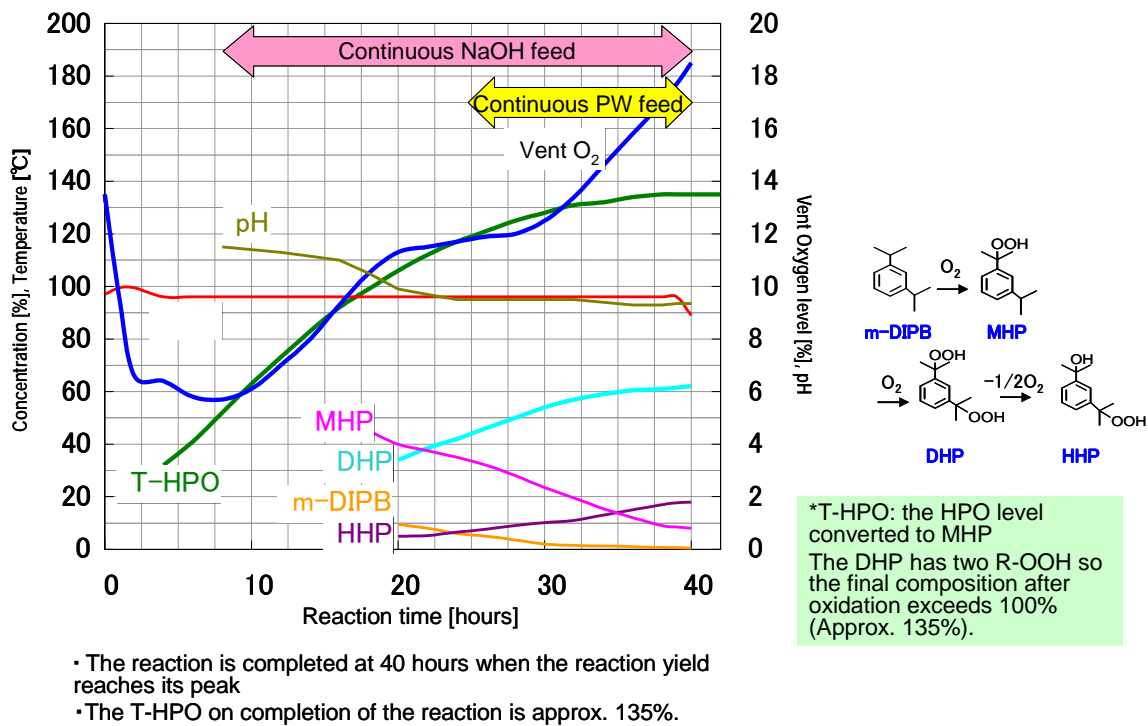

Figure 3-4 Temporal changes in oxidation reaction

4. Causes of the Accident

4-1. Analysis of the events leading to the accident

(1) Organize events in a timeline

The events leading up to the explosion and fire were organized in a timeline.

- April 21 23:20
- The resorcinol oxidation reactor was operating normally. They were 36 hours into the 40 hour batch reaction.
 - The utilities plant had stopped and as a result, the steam supply was stopped and an emergency order was issued to all plants (for plants using 3 kilo steam to stop operations).
- 23:32
- The emergency shutdown (ESD) switch was activated at the resorcinol plant. The interlock was activated properly and the air supply was stopped. The oxidation reaction was stopped and nitrogen was supplied to the reactor to prevent the contents from reaching the explosion range. Additionally, cooling water for the oxidation reactor was switched from circulating water to emergency cooling water (FW).

(Refer to Figure 4-1, 4-2 Oxidation reactor flow)

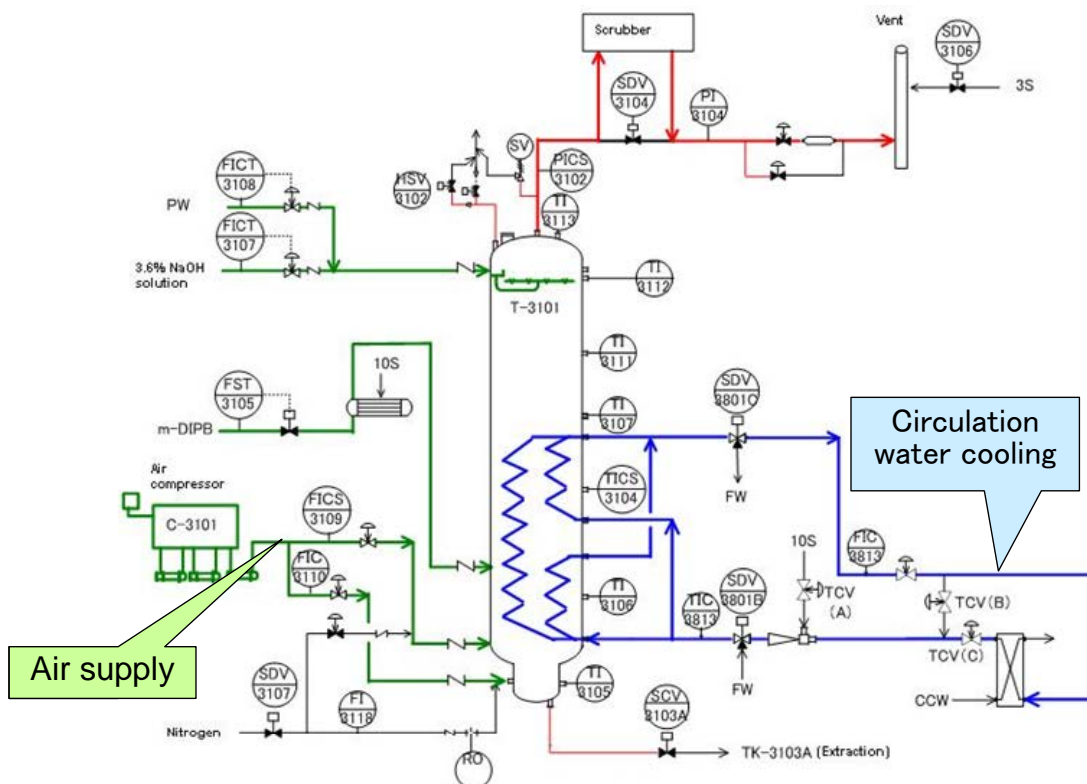

Figure 4-1 Flow during normal operation (Batch reaction started April 21 at 23:32.)

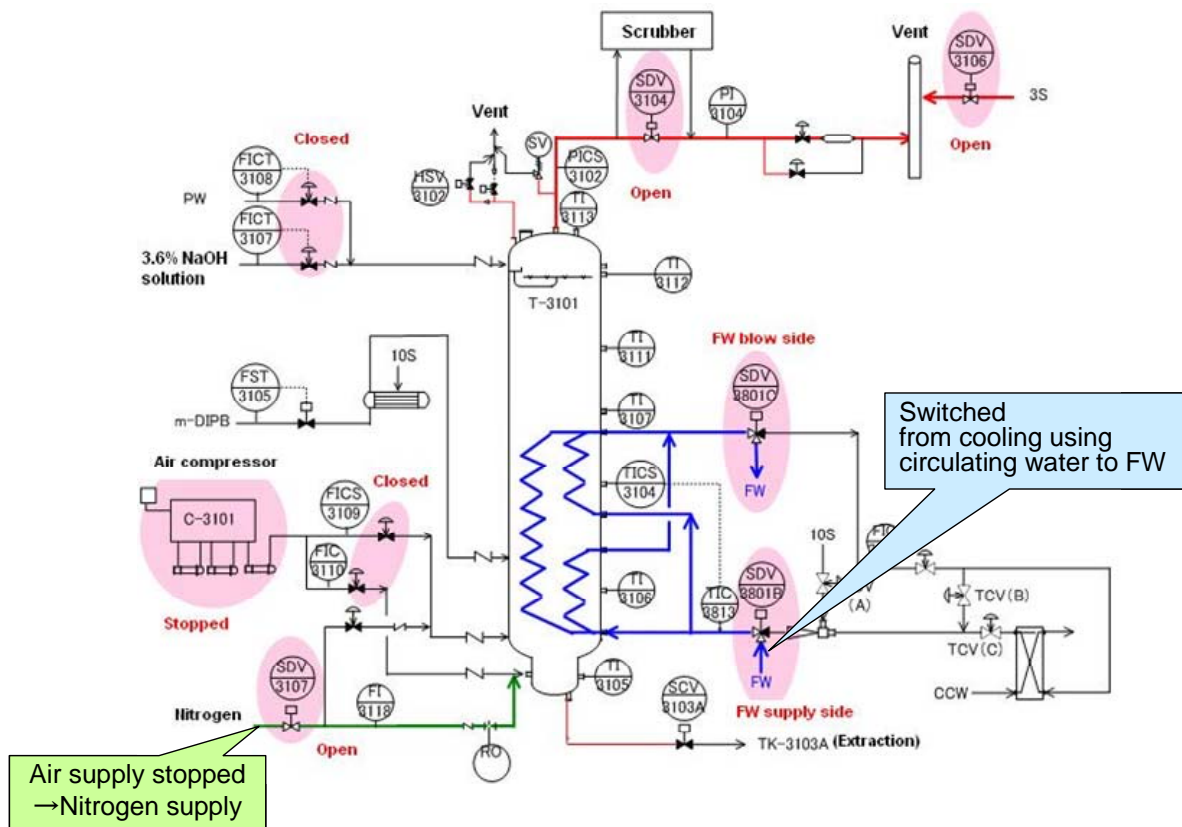

Figure 4-2 Flow during emergency shutdown (ESD) (When the interlock is activated)
 (23:32 on April 21 to 0:40 on April 22)

- ~23:52
 - After the interlock was activated, since the temperature in the lower part of the liquid phase (TICS-3104, with cooling coil) did not drop, the operator checked onsite and found that the onsite pressure for FW was low at 0.3 to 0.4 MPaG. The FW pressure was low and the FW flow was insufficient so the operator thought the reactor temperature would not drop. He made a request to the utilities plant to raise the pressure of the FW and it was raised.
- 23:56
 - The reactor temperature began to drop.
 (Refer to Figure 4-4 Temperature trends)
- April 22
 - After the FW pressure was raised, the operator confirmed that the temperature of the lower liquid phase (TICS-3104, with cooling coil) was starting to drop slightly, but he felt that the cooling speed was too slow, so based on his experience with cooling operations when completing oxidation reactions during regular operation batches, he

thought that circulating water would cool the reactor faster than FW. He decided to switch the cooling water from FW to circulating water.

0:40

- In order to switch the cooling water from FW to circulating water, he released the interlock. By releasing the interlock, the cooling water was switched from FW to circulating water and the nitrogen supply was stopped. As a result, agitation in the oxidation reactor was stopped.

(The operator was not aware at this time that the nitrogen supply had stopped.)

(Refer to Figure 4-3 Flow of the Oxidation Reactor)

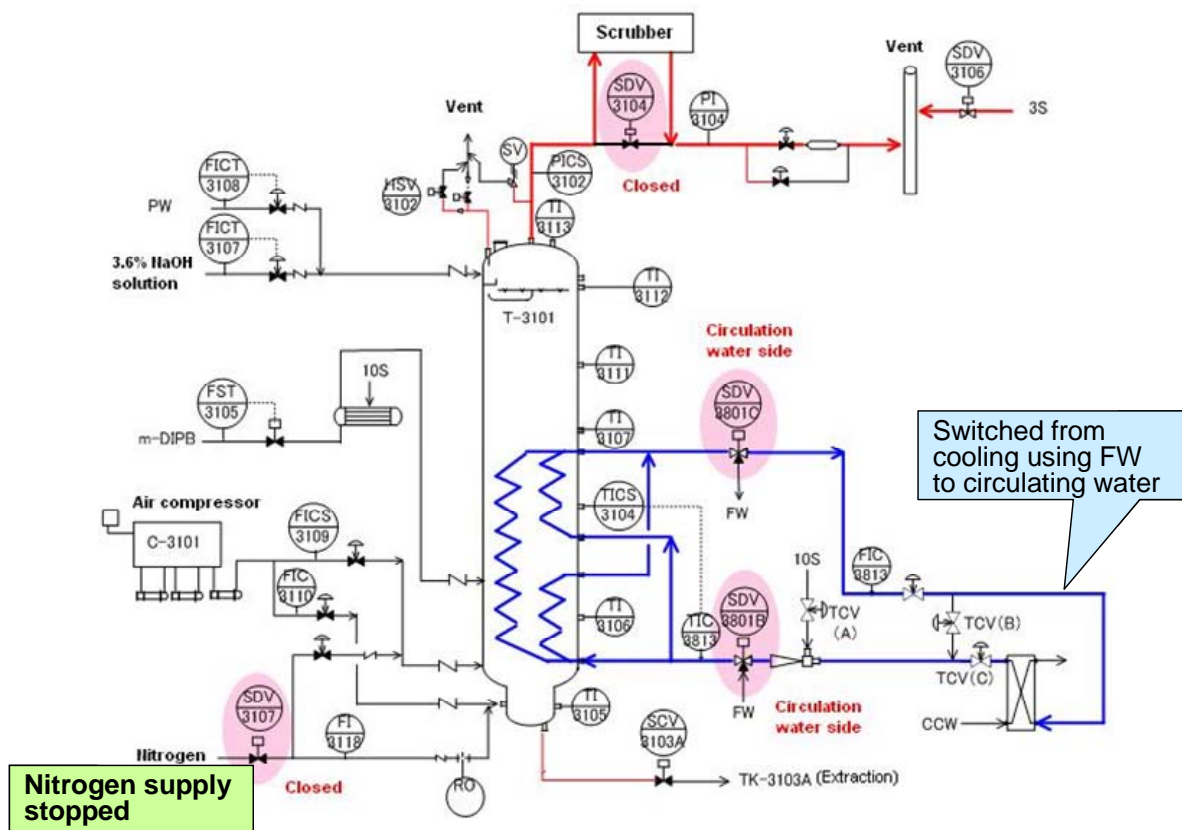
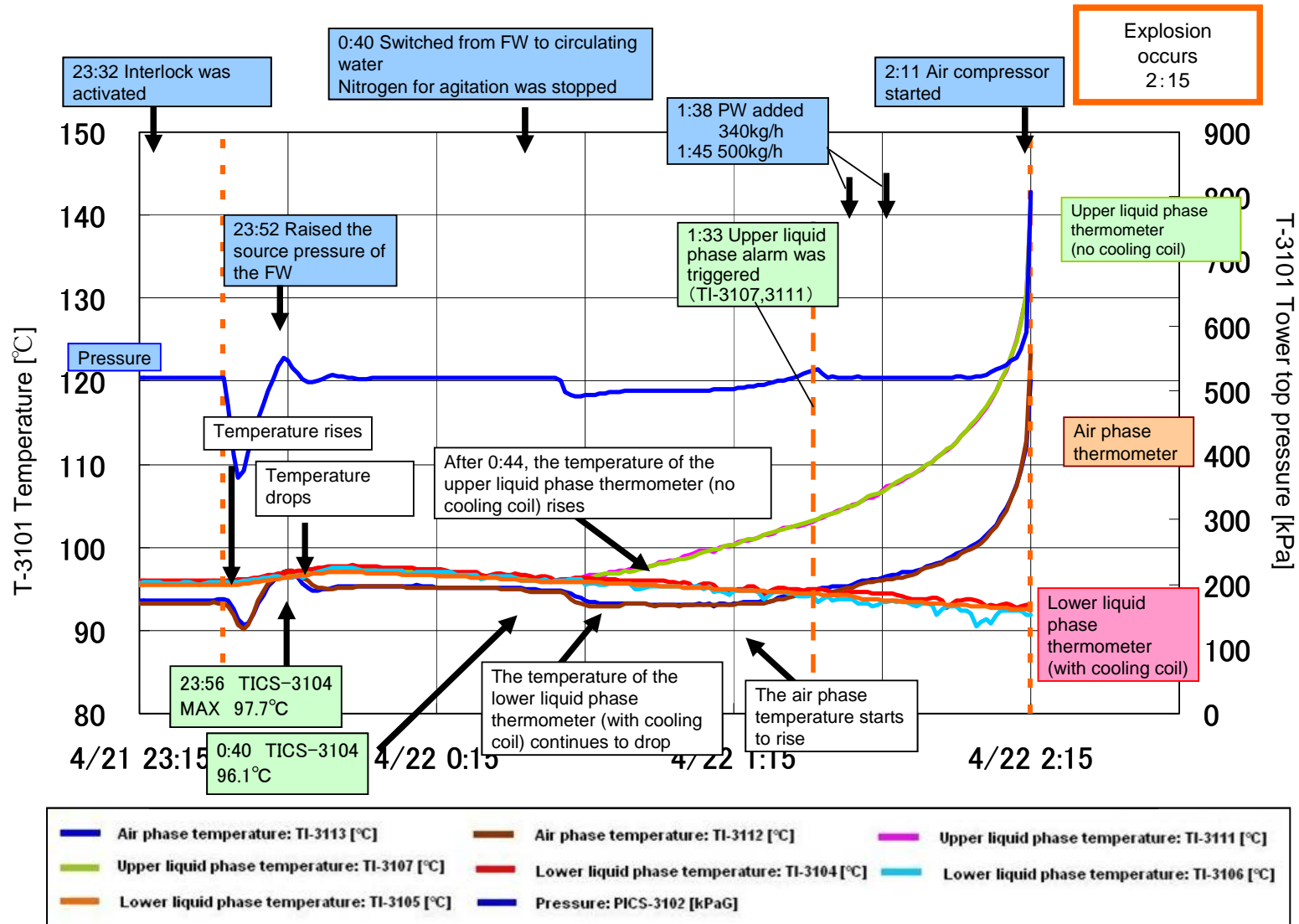

Figure 4-3 Flow for releasing interlock (0:40 to 2:15 on April 22)

- 0:44~
- After the cooling water was switched from FW to circulating water, the temperature in the lower liquid phase (TICS-3104, with cooling coil) continued to drop. At the same time, because the nitrogen supply was stopped and agitation was stopped, the temperature in the upper liquid phase (TI-3107 and TI-3111, no cooling coil) which was the same as the lower liquid phase after the emergency shutdown, began to rise.
- (Refer to Figure 4-4 Temperature trends)
- 1:33~1:38
- The temperature in the upper liquid phase (TI-3107 and TI-3111, no cooling coil) reached 104°C and the high-temperature alarm was triggered, but the operator thought that the temperature was rising in the gas phase and that the temperature was 96 to 97°C and within the range of normal operation. He thought that water would lower the temperature, so he began adding PW from the upper part of the reactor.
- 1:45
- Even though the PW was added, the temperature did not drop. This is when the operator realized that the nitrogen supply for agitation was stopped. He began to confirm the operation condition. He thought that since the oxygen level was 0% that the nitrogen exchange had been successful, and the pressure was 0.52 MPaG which was normal in a controlled situation.
- ~1:59
- After confirming the above operation conditions, he determined that he should start the air compressor as is done in regular operation in order to restart air agitation.
- 2:01
- The gas phase temperature (TI-3112) reached 99.5°C and the high-temperature alarm was triggered.
- 1:59~2:11
- While the operator was preparing to start the air compressor, the temperature in the upper liquid phase (TI-3107, no cooling coil) continued to rise and the pressure also began rising.
- (Refer to Figure 4-4 Pressure trends)
- 2:11~2:14
- The air compressor was started, and when the operator confirmed the pressure, he noticed that it had rose to 0.56 MPaG so he manually opened the pressure adjustment valve (PCV-3102) but the pressure could not be released in time and it continued to rise quickly.
- 2:15
- The pressure exceeded the design pressure of 0.8 MPaG causing the oxidation reactor burst and a fire was started.

Figure 4-4 Operation condition up to the explosion and fire and temperature and pressure trends



(2) Summary of the events leading up to the accident

Figure 4-5 shows the main points of the events that led to the accident in a time series.

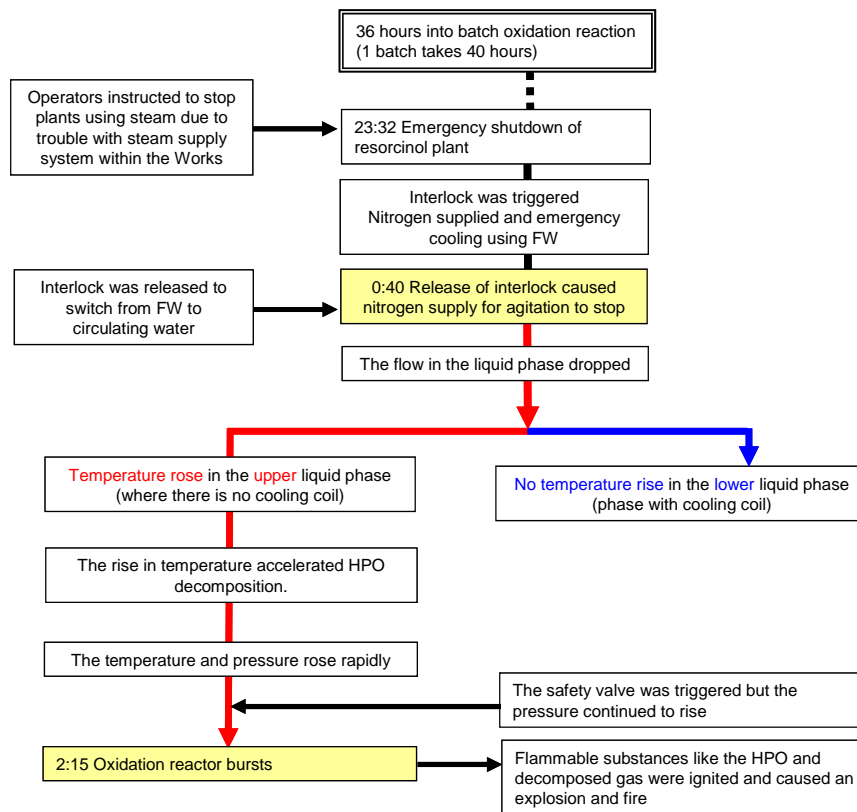

Figure 4-5 Flow of events leading up to the explosion and fire

4-2. Technical verification of the events leading to the accident

The events after 0:40 in the flow above were verified by measuring the heat behavior of HPO decomposition, analyzing the flow of the liquid phase when the supply of nitrogen for agitation is stopped and estimating the temperature and pressure behavior in the reactor when the accident occurred.

(1) Verification of the rise in temperature due to HPO heat decomposition

Based on the data from the conventional differential scanning calorimeter (DSC), it was assumed that sudden rises in temperature during HPO heat decomposition occurred in the range of 150°C or higher. To confirm that the rise in temperature and pressure leading up to the accident was caused by HPO heat decomposition, the heat decomposition behavior of HPO, the main ingredient of

the oxidation reaction liquid, was measured in an insulated accelerating rate calorimeter (ARC).

The sample was created in a small test using the same formula as the actual plant with almost the same composition as 36 hour oxidation using the actual reactor (oxidation reaction time up to emergency shutdown), and when measuring ARC, and the solution used was pre-treated so it had the same heat history as the actual solution. The sample was an emulsion that contained water, so the water was separated and the oil layer was evaluated.

The results of the ARC measurement are as shown in Figure 4-6 and it was confirmed that in an adiabatic condition, when the temperature rises, self-heating is pronounced and both the temperature and pressure rise suddenly.

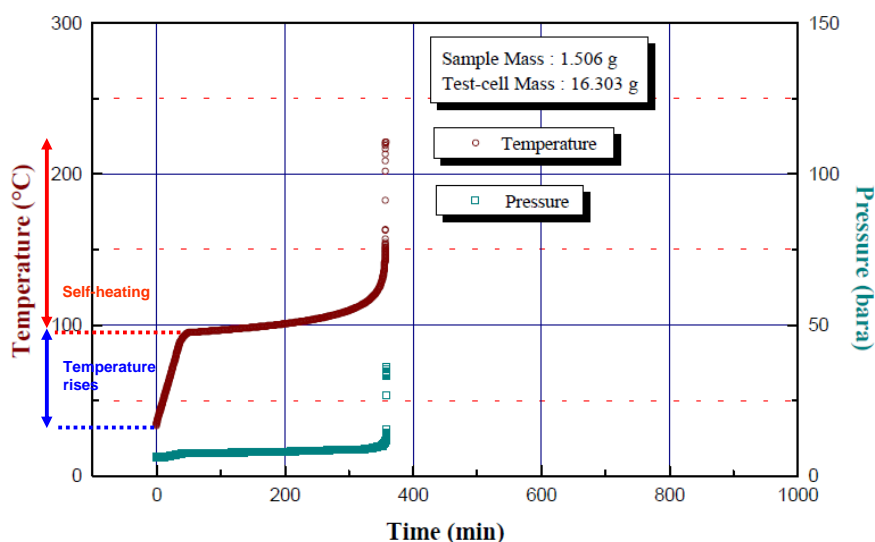

Figure 4-6 Arc measurement results of the oil layer of the small test mixture (after pre-treatment) (Actual measured values)

Next, an Arrhenius plot was used to organize the ARC measurement data and as you can see in behavior of the solutions “with pre-treatment” in Figures 4-7 and 4-8, the changes in temperature were similar to when the explosion and fire occurred with the actual equipment. Therefore, it is assumed that the rise in temperature in the upper liquid phase where there was no cooling coil occurred due to heat decomposition of the HPO under these conditions.

It should be noted that there was a difference in the heating speed when no pre-treatment was conducted, as shown in Figure 4-7.

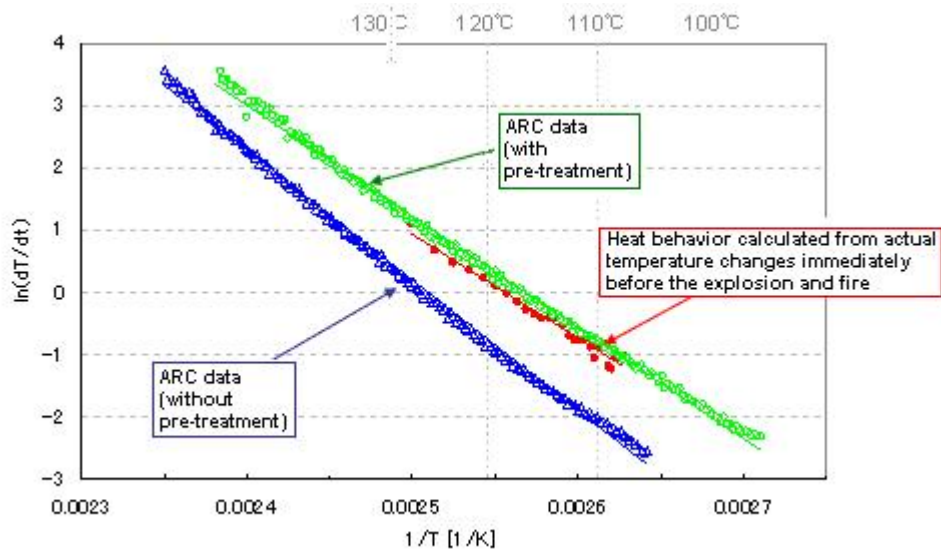

Figure 4-7 Results of ARC analysis of oil layer of the small test solution (with and without pre-treatment) and changes in temperature when the explosion and fire occurred (The unit for dT/dt is [K/min]. Adjusted for specific heat)

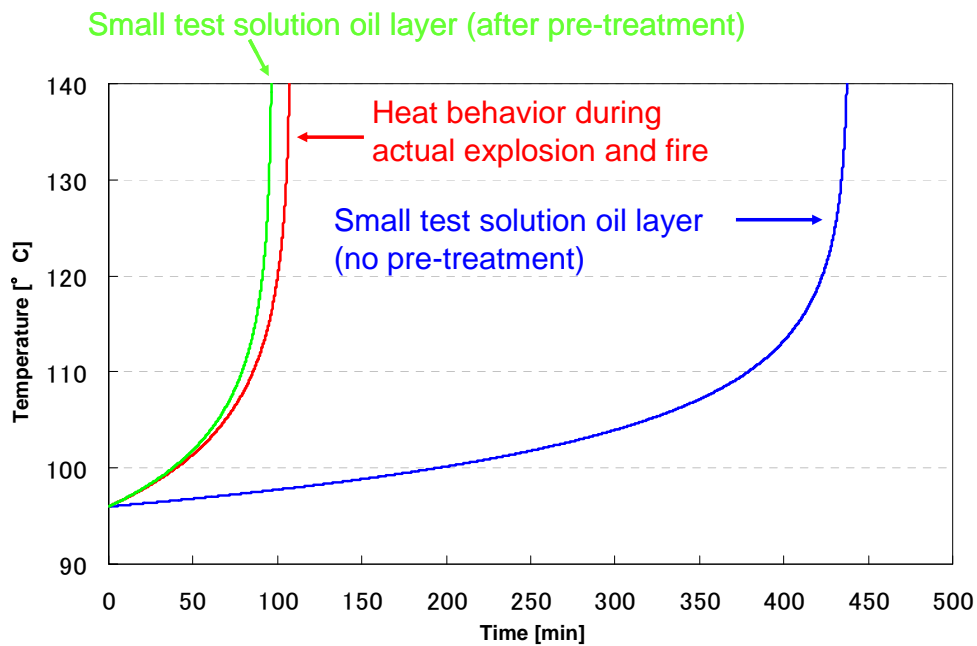

Figure 4-8 Changes in temperature (estimated from the Arrhenius formula)

(2) Verification of the flow conditions and the reaction liquid temperature behavior

As a result of analyzing the flow conditions after the nitrogen supply for agitation was stopped, it was determined that as time passed, the liquid flow throughout the reactor dropped and 15 minutes after the nitrogen supply was

stopped, only a slight upward flow in the draft tube and some flow around the coil could be seen, and the liquid around the upper liquid phase where there was no cooling coil was almost completely still and no liquid was exchanged with the lower liquid phase (Refer to Figure 4-9).

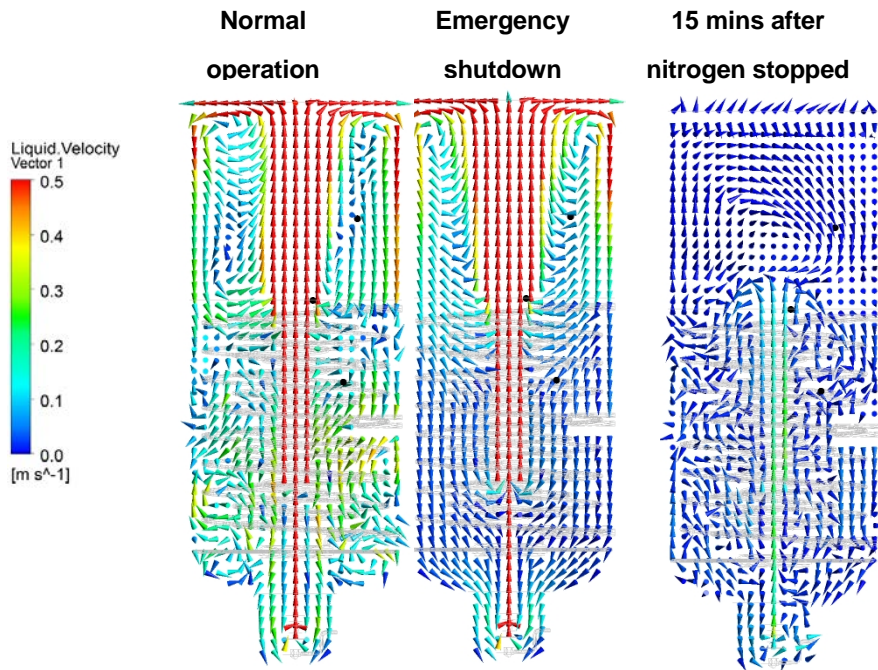

Figure 4-9 Changes in the liquid velocity vector

Additionally, verification was made of the changes in temperature in the upper and lower liquid phases after the nitrogen supply was stopped. The initial temperature of the liquid was set at 96°C and it was assumed from the flow conditions that there was no exchange of liquids between the upper and lower liquid phases. The changes in temperature at each point were calculated based on the heat balance of the HPO decomposition heat and the heat removal from the cooling coils. As a result, the calculated value of the temperature of the oxidation reactor showed similar trends as the actual temperatures recorded the day of the accident (Refer to Figure 4-10). Based on this, it is thought that the temperature in the lower liquid phase dropped gradually as it was cooled and the temperature rose in the upper liquid phase due to the decomposition reaction of the HPO.

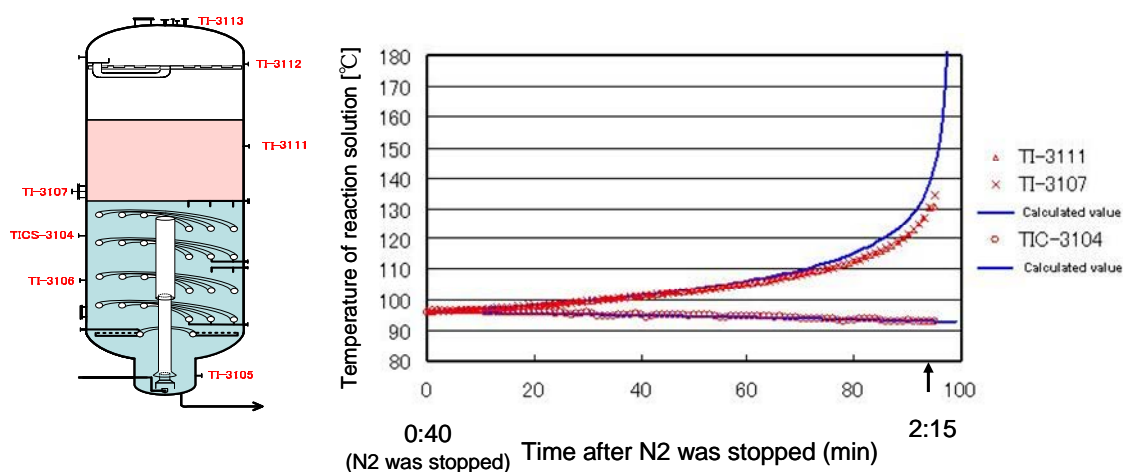
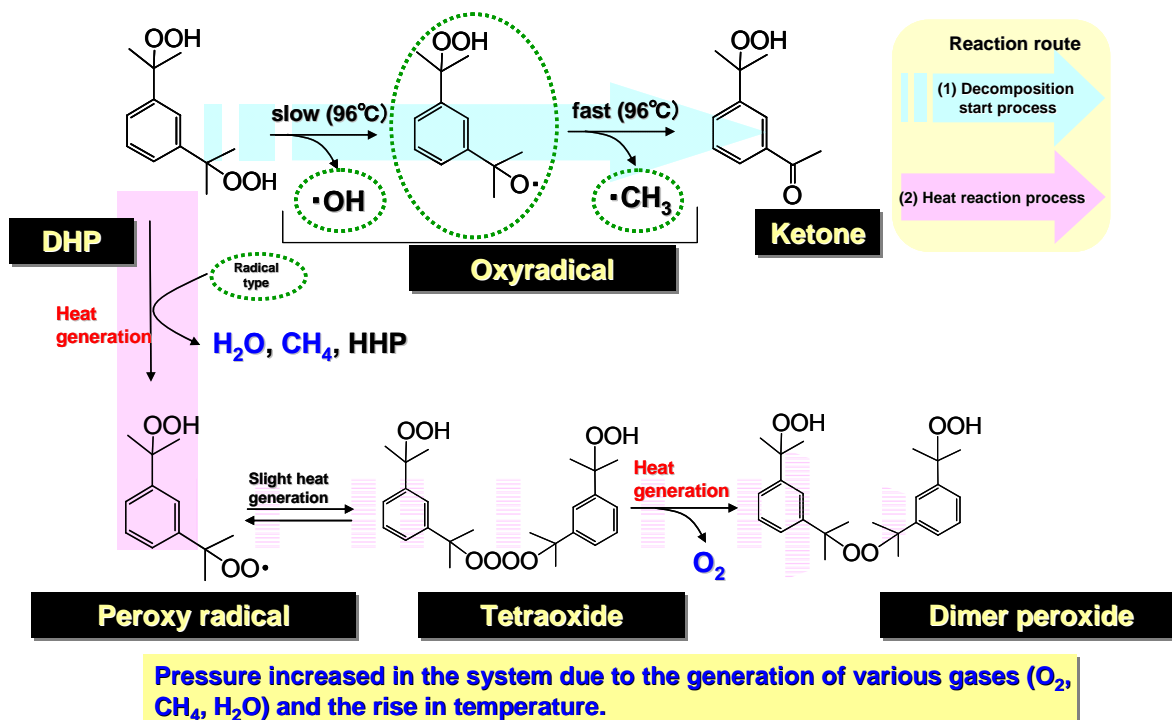

Figure 4-10 Changes in temperature in the oxidation reactor after the nitrogen supply is stopped and results of calculation

(3) Verification of decomposition reaction mechanism

The decomposition reaction mechanism of DHP was estimated using a computational chemistry method. As shown in Figure 4-11, first there is the process when the DHP decomposition begins with the generation of radicals. Next, there is heating reaction process where the radicals and the DHP react to generate peroxy radicals and peroxide dimer. During this heating reaction process, gas is generated from the water, methane and oxygen. Through confirmation of the small test solution in a heat decomposition test, the volume of gas generated tended to increase as the temperature rose, and the composition of the gas was 40 to 60% methane. (Refer to Figure 4-12)

From this, it can be assumed that with the rise in temperature, the radical cleavage and the heating reaction of DHP, a main ingredient of HPO, were gradually accelerated and the amount of gas generated increased as the temperature rose, resulting in the rise in pressure.



*The three types of radicals are highly reactive, so they mostly disappear after reacting with DHP.

Figure 4-11 DHP decomposition reaction mechanism that can be estimated from computational chemistry

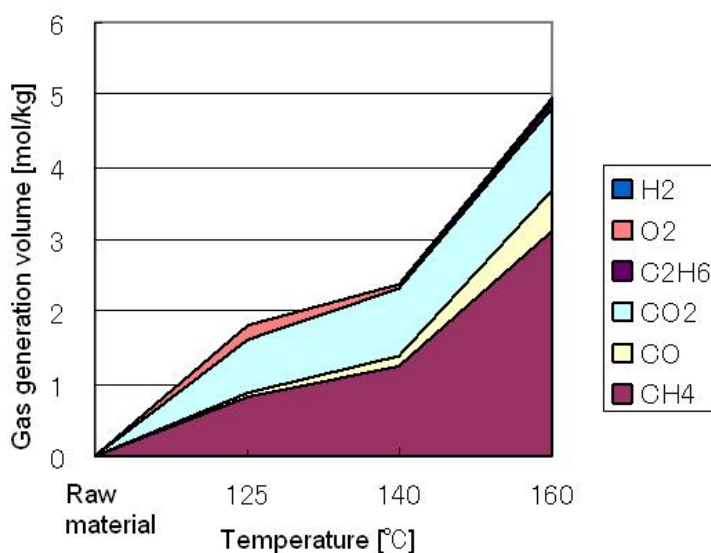

Figure 4-12 Heat decomposition gas composition of small test solution

(4) Verification of pressure rise

Verification was conducted for the phenomenon that caused HPO decomposition leading to a sudden rise in temperature and pressure that burst the oxidation reactor. Based on the speed in which the temperature and pressure rose which were obtained from the ARC measurement results (Fig. 4-6), equation (1) was obtained when determining the speed in which the pressure rose as the speed of gas generation per unit weight (Y :[Nm³/hr/g]). Equation (2) was obtained for the heat generation speed.

$$\ln(Y) = -29223 \frac{1}{T} + 59.512 \quad (1)$$

$$\ln\left(\frac{dT}{dt}\right) = -17831 \frac{1}{T} + 45.808 \quad (2)$$

By solving the two equations as a system of equations, the changes in the temperature, speed of gas generation and pressure over time after the nitrogen supply for agitation was stopped could be estimated as shown in Figure 4-13 and the results showed that the pressure would eventually exceed 10 MPa.

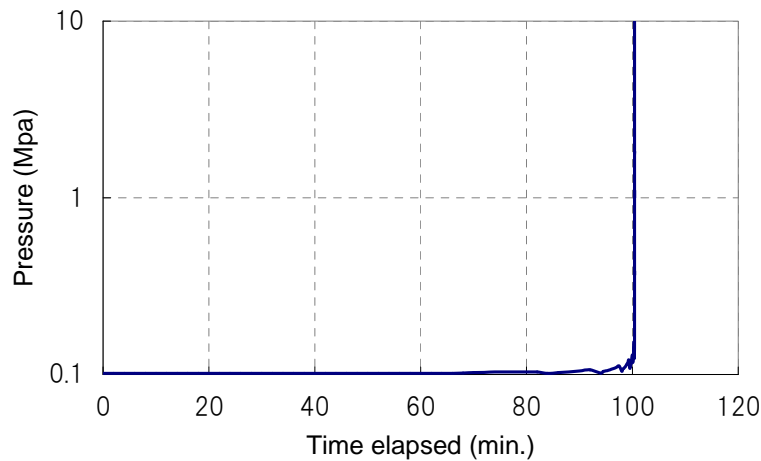

Figure 4-13 Estimated change in pressure over time

Additionally, the internal pressure when the oxidation reactor burst was estimated to be 8 MPa or higher from the elasto-plastic analysis using FEM and the rupture stress of the manhole bolt, and combining that with the results of the calculations above, it is assumed that the rise in pressure from the gas generated caused the reactor to burst.

4-3. Analysis of the direct cause

The direct cause was estimated from the Root Cause Analysis (RCA) and the progress flow analysis (PFA)*, and the primary and secondary factors were extracted.

*Progress flow analysis (PFA): Accident analysis method developed by the National Institute of Advanced Industrial Science and Technology (AIST)

(1) Direct cause

Based on the Flow of events leading to the explosion and fire (Fig. 4-5) shown in the previous section, the events leading up to the rupturing of the oxidation reactor can be summarized as follows.

During the emergency shutdown of the oxidation reactor to generate HPO, the **interlock was released**, stopping the nitrogen supply to the reactor and the agitation of the liquid phase.

There was no cooling coil in the upper liquid phase of the reactor, so the HPO cracking heat that was generated could not be removed and the temperature rose.

The rise in temperature accelerated the cracking reaction of the HPO and the pressure inside the oxidation reactor rose, eventually causing the reactor to rupture.

(2) Primary factors

Using “Released interlock” as a keyword, the following three primary factors were raised putting into consideration why the operator decided to release the interlock, why he actually released the interlock, and why that led to the accident.

- a. The operator decided that he should release the interlock.
- b. The interlock could be easily released.
- c. Releasing the interlock stopped the nitrogen supply for an extended period of time and agitation in the reactor was stopped causing the temperature to rise.

(3) Secondary factors

a. The operator decided that he should release the interlock.

- In order to secure a sufficient flow rate of FW for cooling, it was necessary to raise the source pressure but this could not be done automatically so the operators onsite had to make a request to get the pressure raised.
- The pressure of the FW was raised and sufficient flow rate was secured but the lowering of the temperature was slow.
- The target temperature for maintaining a stable state after emergency shutdown and the target speed for lowering the temperature were not provided in the manual.
- Based on his experience with cooling after the oxidation reaction was completed in a normal batch, the operator decided that it would be better to switch from FW to circulating water.
- The main screen of the DCS shows the temperatures as digital numbers, so it was difficult for operators to see the rate of decline.

b. The interlock could be easily released.

- The manual for emergency shutdown did not include conditions for determining the “stable conditions” for releasing the interlock.
- The operator did not follow the prescribed procedures for releasing the interlock.
- The operator lacked an awareness of the seriousness (importance) of releasing the interlock.

c. Releasing the interlock stopped the nitrogen supply for an extended period of time and the agitation was stopped causing the temperature to rise.

<Regarding stopped agitation>

- The system was designed so that the nitrogen supply would stop if the interlock is released.

<Regarding rise in temperature>

- Once the agitation stopped, the upper part of the liquid phase could not be cooled.
- The thermometer that triggers the interlock was only installed in the lower part of the oxidation reactor.

<Regarding the delay in noticing that the agitation had stopped and the temperature was rising>

- There was no alarm to detect that the supply of the agitation gas had stopped.
- The main screen of the DCS did not show the nitrogen flow rate.
- It was difficult to understand the temperature distribution of the oxidation reactor on the DCS screen when the agitator was stopped.
- The operator did not confirm the instructed temperature in relation to the position of the thermometer and so he did not notice the abnormal rise in temperature for a long time.
- The fact that the nitrogen supply is stopped when the interlock is released was not written in the manual or training materials.
- The operator lacked awareness of the importance of agitation, so though he knew that the nitrogen feed would stop if the interlock was released, he did not notice at the time.
- The operators were not clearly notified of the temperature at which HPO starts decomposition, so the operator did not notice the rise in temperature until later.
- The operator lacked technical knowledge regarding the HPO heat decomposition behavior.

5. Measures to Prevent Recurrence

Tangible (hardware) measures relating to equipment and intangible (software) measures relating to factors that affected decisions and actions of operators that led to the accident were considered as measures to prevent recurrence.

Iwakuni-Ohtake Works shall securely implement the following measures to prevent recurrence.

5-1. Development of measures for direct causes

The primary and secondary factors relating to the direct cause of the accident were obtained multilaterally. Table 5-1 shows an overview of the direct cause measures derived for the secondary factors. The 15 measures for direct causes listed here correspond with each of the secondary factors. In order to expand the 15 measures for direct causes in Table 5-1 to specific measures to prevent recurrence, they were divided into two groups.

A: inherent measures to prevent accidents (tangible and intangible)

B: measures to improve management and technology of emergency operations (tangible and intangible)

The items were then reorganized into the 7 items shown in Table 5-2.

5-2. Inherent measures to prevent accidents

The direct cause of this explosion and fire was the release of the interlock that stopped the nitrogen supply to the oxidation reactor. This in turn stopped the liquid agitation so that the heat in the upper liquid phase (with no cooling coil) could not be removed. This led to a rapid rise in temperature and pressure in the oxidation reactor due to HPO decomposition and the heat it generated.

Inherent measures to prevent this type of accident are measures to immediately cool the oxidation reactor after emergency shutdown, and measures to create a “stable condition” where the HPO decomposition reaction can be suppressed securely (and interlock can be released safely). Additionally, it is necessary to clarify the “stable conditions” in which the interlock can be released. To this end, clear operation management values must be provided based on the latest heat decomposition behavior, and all operators must be notified of these values and use them properly.

The following are details of specific measures established for both the tangible (hardware) aspects relating to the equipment and the intangible (software) aspects that affect decisions and behaviors.

Table 5-1. Outline of the direct causes, factors and measures

<Items>

A: Inherent measures to prevent accidents

B: Measures to improve management and technology of emergency operations

*Corresponds with the class and Nos. in Table 5-2

Direct causes	Primary factors	Secondary factors	#	Type	Target items	Class*	
<p>[The interlock was released.]</p> <p>The interlock of the oxidation reactor used to create HPO was released during emergency shutdown, and the nitrogen supply was stopped causing the agitation of the liquid phase to stop.</p> <p>As a result, the HPO decomposition heat could not be removed in the upper liquid phase where there were no cooling coils, and the temperature rose.</p> <p>Due to the rise in temperature, the decomposition reaction of the HPO was accelerated, the pressure rose in the oxidation reactor and the reactor burst.</p>	1) The operator decided that he should release the interlock.	In order to secure a sufficient flow rate of FW for cooling, it was necessary to raise the source pressure but it could not be done automatically so the operator onsite had to make a request to get the pressure raised.	1	Tangible	Show the FW pressure and flow rate on the DCS screen.	A (1)	
		The pressure of the FW was raised and sufficient flow rate was secured but lowering of the temperature was slow. (Why the operator felt that the temperature was slow to drop in the oxidation reactor after emergency shutdown)	2	Tangible	Create a system to promptly raise FW pressure after an emergency shutdown.	A (1)	
		The target temperature for maintaining a stable state after emergency shutdown and the target speed for lowering the temperature were not provided in the manual.	3	Tangible	Secure the necessary cooling ability (cooling ability that is effective enough to significantly lower the temperature after an emergency shutdown).	A (1)	
		Based on his experience with cooling after the oxidation reaction was completed in a normal batch, the operator decided that it would be better to switch from FW to circulating water.	4	Intangible	Set the target values for the "stable condition (such as target speed of temperature reduction)" in which the interlock can be released during emergency shutdown and notify operators (manuals, training).	A (2) A (3)	
		The main screen of the DCS shows the temperatures as digital numbers, so it was difficult for operators to see the rate of decline.	5	Tangible	Create a DCS screen where it is easy to see temperature dropping trends after emergency shutdown.	B (5)	
	2) The interlock could be easily released.	The manual for emergency shutdown did not include conditions for determining the "stable conditions" for releasing the interlock.	6	Intangible	Set standards for the "stable condition" in which the interlock can be released during emergency shutdown and add the standards to the manual.	A (2)	
		The operator did not follow the prescribed procedures for releasing the interlock.	7	Intangible	Educate operators on the importance of interlock operations	A (2)	
		The operator lacked the awareness of the seriousness (importance) of releasing the interlock.			Clearly notify operators of the section rules regarding releasing interlock and authorization routes.		
	3) Releasing the interlock stopped the nitrogen supply for an extended period of time and the agitation was stopped causing the temperature to rise.	Agitation was stopped.	The system was designed so that the nitrogen supply would stop if the interlock is released.	8	Tangible	Measures to ensure releasing interlock does not stop agitation.	A (1)
		The temperature rose.		9	Intangible	Review risk of emergency shutdown (HAZOP, etc.)	B (7)
		Once the agitation stopped, the upper part of the liquid phase could not be cooled.	10	Tangible	Secure agitation conditions and cooling conditions.	A (1)	
		The thermometer that triggers the interlock was only installed in the lower part of the oxidation reactor.	11	Tangible	Install thermometers for interlock at multiple points (Upper and lower parts) of the oxidation reactor.	B (4)	
		Delay in realizing that the agitation was stopped and the temperature was rising.	12	Tangible	Review DCS screen and alarm to ensure operators can easily confirm the agitation status and temperature distribution of the reactor during emergency shutdown.	B (5)	
		There was no alarm to detect that the gas for agitation was stopped.					
		The main screen of the DCS did not show the nitrogen flow rate.					
It was difficult to confirm the temperature distribution in the oxidation reactor when the agitation is stopped.							
The operator did not confirm the relationship between the position of thermometer and the indicated temperature, so it took a long time for him to realize the abnormal rise in temperature.							
The fact that the nitrogen supply is stopped when the interlock is released was not written in the manual or training materials.		13	Intangible	Educate and notify operators of the details of process actions such as nitrogen being stopped when the interlock is released.	B (6)		
The operator was not fully aware of the importance of agitation so though he knew that the nitrogen would be stopped if the interlock is released, but he did not notice it at the time.	14	Intangible	Educate operators on the importance of agitation in the oxidation reactor and Review the DCS screen to make it easier for operators to confirm the operation condition during emergency shutdown and review the alarm.	B (6) B (6)			
The operators were not clearly notified of the temperature at which HPO begins decomposition, so the operator did not notice the rise in temperature until much later.	15	Intangible	Obtain data on the heat decomposition behavior of HPO (such as ARC). • Educate operators on hazard information and pass down skills • Reflect the information in the safety design philosophy of the plant (settings for temperature alarms, manuals)	A (3)			
The operator lacked technical knowledge regarding the heat decomposition behavior of HPO.							

Table 5-2. Measures in response to the direct cause

Classification	#	Items of measures in response to the direct cause	Response No.*
A: Inherent measures to prevent accidents (Tangible and intangible measures)	(1)	Secure the necessary capability for cooling the oxidation reactor during emergency shutdown 1) Cooling capability necessary to achieve significant temperature reduction (raise the heat transfer area of the cooling coils, expand the installation range) 2) Strengthen system to promptly raise the FW pressure and monitoring 3) Maintain agitation condition of oxidation reactor	1, 3 2 8, 10
	(2)	Clarify the conditions in which the interlock can be released 1) Set the standards for "stable condition (such as temperature)" which is the condition in which interlock can be released during emergency shutdown 2) Create and use a checklist to use when releasing interlocks <ul style="list-style-type: none"> ▪ Confirm "stable conditions" ▪ Authorization from superiors, etc. 	4 4, 6, 7
	(3)	Review temperature management based on the HPO heat decomposition behavior data collected using the latest methods (ARC, etc.) and notify employees 1) Collect HPO heat decomposition data 2) Reflect in the safe design philosophy 3) Educate employees on the hazard information for HPO and make sure skills are passed down	15 4, 15 4, 15
B: Improve management and technology of emergency operations (Tangible and intangible measures)	(4)	Install multiple thermometers that trigger the interlock in the oxidation reactor	11
	(5)	Create a DCS screen where abnormal conditions during emergency shutdown can be detected easily and review the alarms <ul style="list-style-type: none"> ▪ Agitation condition (display nitrogen flow rate, install alarm for when agitation gas is stopped) ▪ Temperature distribution (Improve screen display and alarm sounds, etc.) ▪ Temperature trends 	5, 12, 14
	(6)	Create training material regarding interlock and conduct training <ul style="list-style-type: none"> ▪ Importance of agitation in oxidation reactors ▪ Rules within the section regarding releasing interlock and authorization routes ▪ Details of process actions after interlock is released 	13, 14
	(7)	Review operation procedures for emergency shutdown of oxidation reactors and equipment risks	9

*Corresponds to the numbers on Table 5-1

- (1) Secure the necessary capability for cooling the oxidation reactor during emergency shutdown

The basic point is to increase the heat transfer area of the cooling coils, expand the installation range, secure a stable supply of FW and continue nitrogen agitation to ensure that the oxidation reactor can be swiftly cooled after emergency shutdown.

- 1) Cooling capability necessary to achieve significant temperature reduction (Increase the heat transfer area of the cooling coils, expand the installation range) (Tangible measures)

Expand the installation range of the cooling coils to the still liquid surface of the upper liquid phase. Also design the coil heat transfer area to provide the necessary heat removal capability during emergency shutdown. An image of the changes in the cooling coil is shown in Figure 5-1.

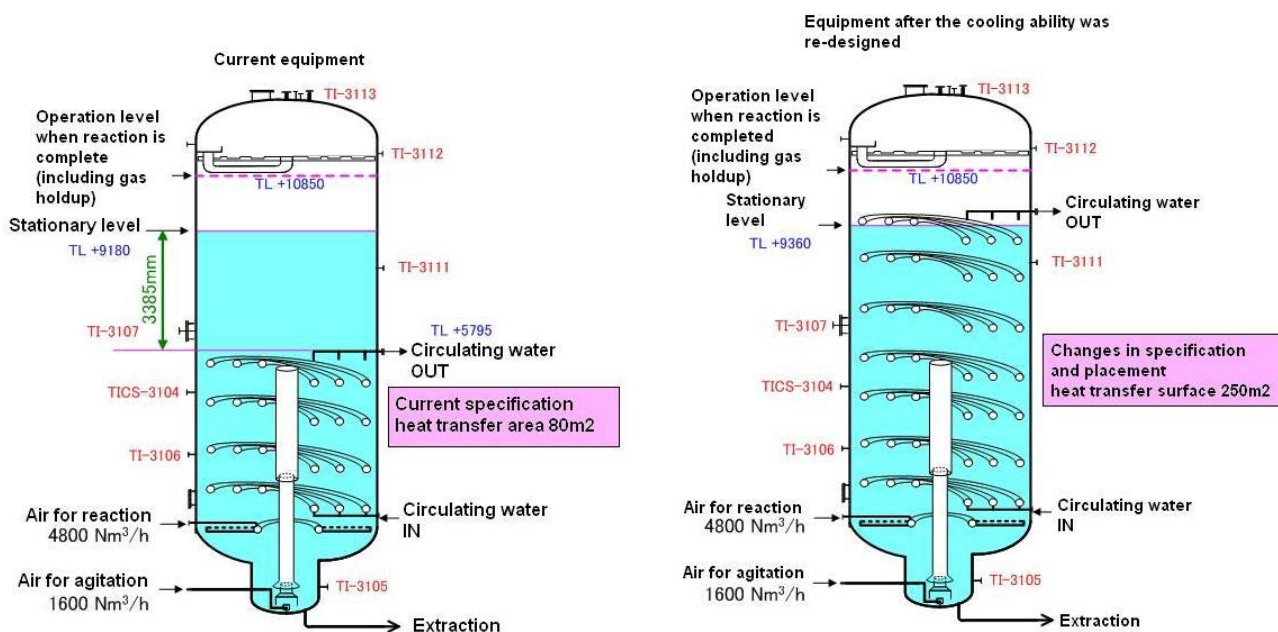

Figure 5-1 Changes in the cooling coil

- 2) Strengthen system to promptly raise the FW pressure and monitoring (Tangible measures)

In order to swiftly secure FW flow rate immediately after emergency shutdown, establish a system whereby the FW pressure can be raised without making a request (by phone) from the resorcinol plant in the event

of an emergency. When the interlock of the resorcinol oxidation reactor is triggered, a signal can be sent to the utilities plant and when the beacon light on the utilities side is triggered, pressure can be raised at the utilities plant. Additionally, the FW flow rate and pressure shall be added to the resorcinol plan DCS so that operators can confirm the FW flow rate and detect problems early on.

3) Maintaining agitation in oxidation reactors (Tangible measures)

Change the system so that when the interlock is released, the nitrogen supply is not automatically stopped and agitation is maintained. The operation details when the interlock is released were changed as shown in Figure 5-2. Additionally, in order to detect when agitation is stopped, an alarm will be triggered whenever the agitation air or nitrogen is stopped.

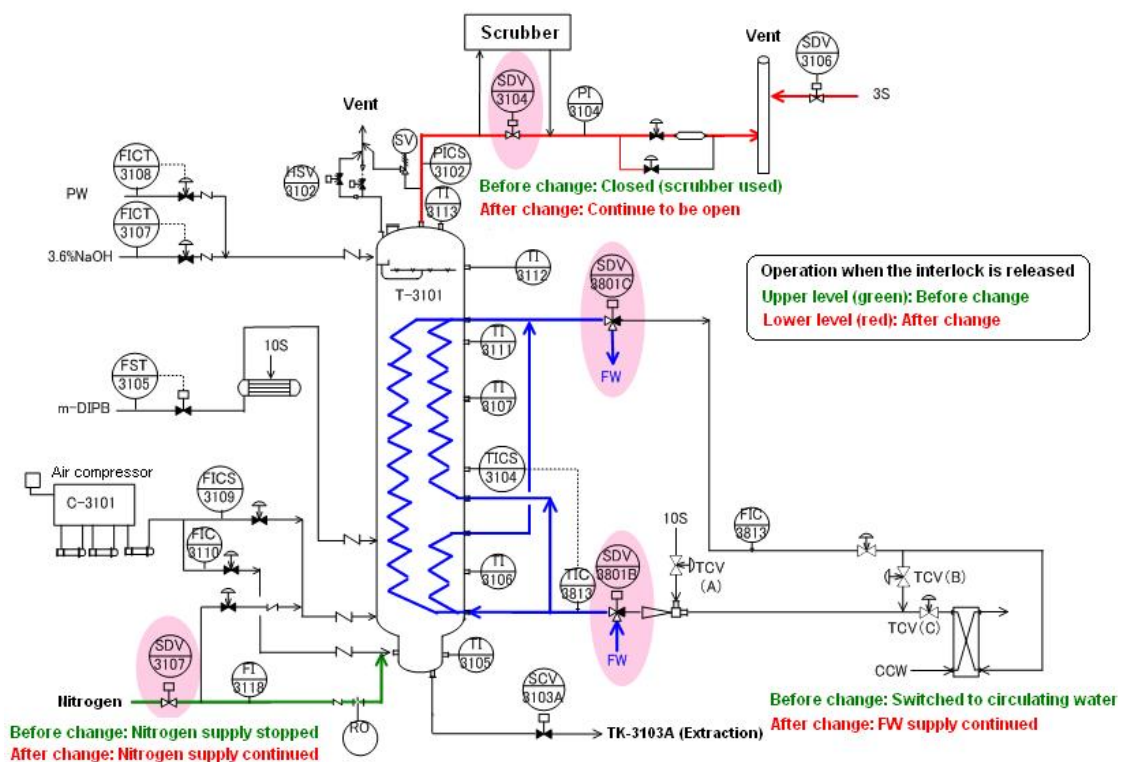

Figure 5-2 Flow for releasing the interlock

(2) Clarify the conditions in which the interlock can be released

The standards for the “stable condition” in which the interlock could be released shall be clearly stated in the manual and everyone shall be notified of the confirmation and authorization items required when releasing the interlock.

1) Set standards for the “stable condition (such as temperature)” in which the interlock can be released during emergency shutdown (Intangible measures)

The “stable condition” of the oxidation reactor after emergency shutdown means the condition in which the oxidation reaction is stopped through nitrogen replacement, the HPO decomposition heat is sufficiently lower than the heat removing ability of the reactor and the gas phase is maintained outside the explosive range. The “stable condition” is a condition in which both of the following points are met and if both points are not met, the interlock must not be released.

Temperature: 80°C or lower (to inhibit HPO decomposition)

Oxygen level: 1% or less

(Oxidation reaction stopped, m-DIPB explosion range avoided*)

*m-DIPB explosion limit oxygen level: 8%

2) Create and use a checklist for releasing interlocks (Intangible measures)

Clarify the procedures regarding release of interlock and confirmation items and create a checklist for conditions when releasing interlock to prevent operators from releasing interlocks easily. Interlocks should only be released after the chief has confirmed the “stable condition” of the oxidation reactor and operators shall follow the procedures for releasing interlock.

(3) Review temperature management based on the HPO decomposition behavior data using the latest methods (ARC, etc.) and notify workers

The heat decomposition behavior data was collected using the latest measurement methods (such as ARC). Based on this data, specify the safety measures for when the interlock is activated and the operation management values. Additionally, include the safety design philosophy for emergency shutdown in the manual.

5-3. Improvement of management and technology of emergency operations

In addition to inherent measures to prevent accidents, improvements will be made to the management and technology of emergency operations for factors that triggered the accident in order to develop more secure measures to prevent recurrence.

Specifically, the measures are installing multiple thermometers that trigger the interlock, creating a DCS screen made especially for emergency shutdown operations of oxidation reactors (tangible measures) and providing training on activation and release of interlocks and reviewing the risks involving emergency shutdown operations and equipment (intangible measures).

(4) Install multiple thermometers that trigger the interlock of the oxidation reactor (tangible measures)

In the safe design philosophy of oxidation reactors, the most important thing is to prevent decomposition reaction in HPO due to a rise in temperature in the oxidation reactor. This is why the liquid phase thermometer is included in the interlock factor. So in order to secure safety regarding partial rises in temperature within the liquid phase, multiple thermometers that trigger the interlock in the oxidation reactor must be installed. There is currently one thermometer to detect the interlock temperature, so the detection points shall be increased to four points in the liquid phase and if any one of the thermometers meets the condition for interlock, then the interlock will be activated.

(5) Create DCS screen in which it is easy to notice problems during emergency shutdown and review the alarms (tangible measures)

Create a DCS screen where operators can easily confirm information (temperature, pressure, nitrogen flow rate, FW flow rate, oxygen level, etc.) that could lead to the early detection of problems with the condition of the emergency shutdown in the oxidation reactor. Additionally, implement measures to detect important information. For example, create an agitation monitoring sequence (monitor flow rate of air or nitrogen for agitation) and set repetitive alarms that are triggered when the agitation is stopped.

(6) Create training material and conduct training regarding interlocks (intangible measures)

Revise the manual to ensure operators are properly trained regarding the interlocks, add to the training plan and conduct training according to that plan.

(7) Review the operation procedures for emergency shutdown of the oxidation reactor and equipment risk (intangible measures)

Review the emergency shutdown operations and equipment risk to prevent the recurrence of similar accidents.

6. Analysis of Underlying Causes and Measures to Prevent Recurrence

Iwakuni-Ohtake Works has continued their efforts in various safety activities based on MCI's management policy, "Safety is our top priority," and the company-wide policies regarding safety activities by weaving in the Works' issues in the action plan. However, considering the gravity of this tragic accident, it is necessary for them to consider and propose improvements to their safety efforts.

Iwakuni-Ohtake Works shall implement measures to prevent recurrence for the direct causes, while also implementing measures for the background, underlying causes to make further improvements and to rebuild the Works into a safe environment. The Head Office shall cooperate with the Works to promote these efforts and hold discussions to make fundamental improvements in safety.

6-1. Analysis of underlying causes

An overview of the analysis as a whole is shown in Figure 6-1. Next, an overview of the analysis results of each method is shown in Table 6-1.

(1) Analysis from expansion of the direct cause

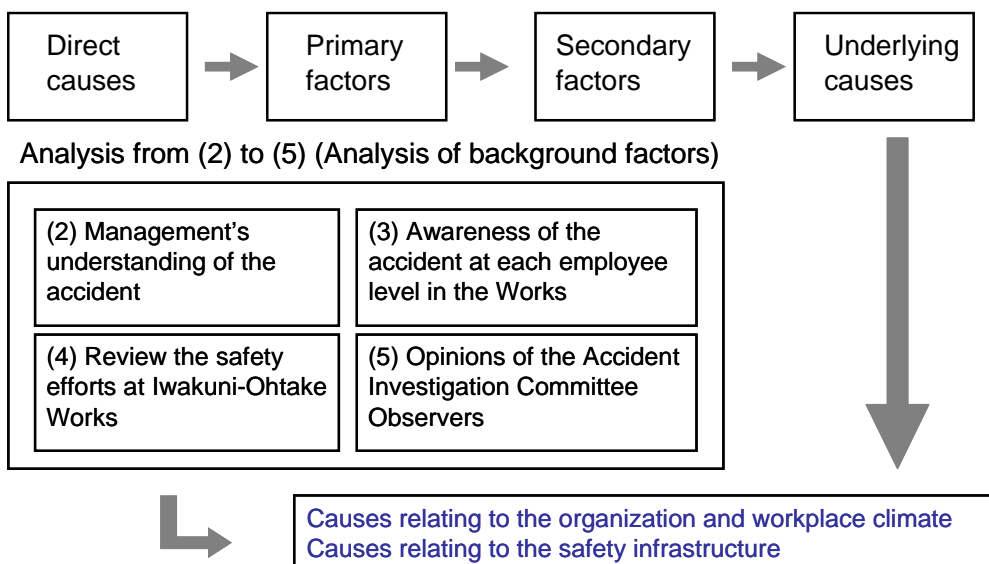

Figure 6-1 Flow chart of Analysis of underlying causes

Analysis method	Overview of Analysis Results
(1) Expansion of the direct cause	The underlying causes expanded from the secondary factors of the direct cause were “insufficient risk assessment”, “insufficient passing down of skills”, and “disregarding regulations and rules”.
(2) Management’s understanding of the accident	A questionnaire was used to confirm the management’s understanding of the accident and extract underlying causes. The results obtained were “insufficient risk assessment”, “insufficient passing down of skills”, “decline in onsite safety management capability”, and “lack of ownership regarding safety/hazards”.
(3) Awareness of the accident at each level of the Works	Based on the direct opinions of each employee level at the Works, hearings were held in order to investigate issues in the organization and climate at Iwakuni-Ohtake Works and its causes. These included hearings by employee level, hearings by organization, and deliberations with Works management. The underlying causes extracted from these hearings were “disregarding regulations and rules”, “decline in onsite safety management capability”, and “lack of ownership regarding safety/hazards”.
(4) Review efforts in safety made at Iwakuni-Ohtake Works	The main activities implemented at Iwakuni-Ohtake Works during the past five years were reviewed and issues relating to organization and workplace climate were extracted. Specifically, activities such as the “MKI activities” [*] used to improve communication throughout the Works, and “Hazard Prediction (KY) activities” to increase sensitivity to hazards were reviewed. The underlying factors extracted were “insufficient risk assessment”, “decline in onsite safety management capability”, and “lack of ownership regarding safety/hazards”.
(5) Opinions of observers on the Accident Investigation Committee	Observers were asked to give their opinions regarding how the workplace climate at Iwakuni-Ohtake Works appears from outside the company. The underlying causes extracted based on their responses were “insufficient risk assessment”, “disregarding regulations and rules”, “decline in onsite safety management capability” and “lack of ownership regarding safety/hazards”.

Table 6-1 Overview of analysis results of underlying causes

*MKI activities: MKI activities are activities conducted to revitalize communication within the Works and are composed of three parts, “See the actual site, actual equipment and actual situation accurately (M)” , “Listen with appreciation and a straightforward attitude (K)” , and “Speak your honest and serious opinions actively and in a constructive manner (I)” .

The underlying causes for safety infrastructure were “Insufficient risk assessment”, “Insufficient passing down of skills”, and “Disregarding regulations and rules” and for organization and workplace climate, the underlying causes were “Decline in onsite safety management capability” and “Lack of ownership regarding safety/hazards”.

Additionally, the underlying causes for organization and workplace climate were classified into more detailed causes. For “Decline in onsite safety management capability”, there is “Difference in the understanding of the reality of “Safety is our top priority” between employee levels”, “Insufficient knowledge and awareness of explosions and fires”, and “Decline in level of engineers”. As for the lack of ownership, it included items such as “Insufficient enforcement of safety activities and follow-up”, “Insufficient efforts by the line manager to improve their workplace”, and “Decline in sensitivity towards hazards”.

Based on these results, the underlying causes can be summarized as follows.

<Underlying causes regarding safety infrastructure>

1. Insufficient risk assessment
2. Insufficient passing down of skills
3. Disregarding regulations and rules

<Underlying causes regarding organization and workplace climate>

4. Decline in onsite safety management capability
 - 4-1. Difference in the understanding of the reality of “Safety is our top priority” between employee levels
 - 4-2. Insufficient knowledge and awareness of explosions and fires
 - 4-3. Decline in level of engineers
5. Lack of ownership regarding safety/hazards
 - 5-1. Insufficient enforcement of safety activities and follow-up
 - 5-2. Insufficient efforts by the line manager to improve their workplace
 - 5-3. Decline in sensitivity towards hazards

We considered the underlying causes of the points raised in the analysis results and extracted the following keywords.

“Commitment of Line Managers”

“Enforcement of safety activities”

“Alertness throughout the Works”

It is necessary to put these factors into consideration when implementing measures to prevent recurrence for underlying causes relating to organization and workplace climate.

6-2. Measures to prevent recurrence for underlying causes

Table 6-2 shows the underlying causes and policies extracted from the analysis conducted in 6-1.

Table 6-2 Summary of Underlying Cause Analysis Results

Underlying Causes		Policies	
Iwakuni-Ohtake Works Factors regarding the safety infrastructure			
[1]	Insufficient risk assessment	(1)	Review the change control flow for cases where highly hazardous substances are handled
		(2)	Create a system to securely conduct risk assessment of emergency shutdowns in cases where highly hazardous substances are handled
[2]	Insufficient passing down of skills <ul style="list-style-type: none"> ▪ Communicate information regarding safety from the design staff to the operation staff ▪ Make efforts to continue passing down skills 	(1)	Improve the passing down of skills based on the emergency shutdown safety philosophy and operation results
		(2)	Ensure that information regarding safety is communicated when there is a change in manager
		(3)	Review important emergency shutdown training relating to safety
		(4)	Training engineers
[3]	Disregarding regulations and rules (Insufficient compliance and review)	(1)	Ensure that the rules are followed when releasing the interlock
		(2)	Review the conditions in which the interlock can be released after emergency shutdown and notify operators
Iwakuni-Ohtake Works Factors relating to organization and climate			
[4]	Decline in onsite safety management capability (Overconfident that safety has been secured)	(1)	Bridge the gap in the understanding of the reality of "Safety is our top priority" between employee grade levels
		(2)	Improve knowledge and awareness of explosions and fires
		(3)	Improve technical skills of engineering staff
[5]	Lack of ownership regarding safety/hazards (Lack of alertness and sense of crisis)	(1)	Enforce safety activities and follow-up
		(2)	Promote improvements in the workplace by the line manager
		(3)	Raise sensitivity towards hazards

Based on these policies, Iwakuni-Ohtake Works shall securely implement the following specific measures to prevent recurrence.

[1] Insufficient risk assessment

- (1) Review the change control flow for cases in which highly hazardous substances are handled

At the resorcinol plant, problems with emergency shutdown could not be extracted during change control relating to operation conditions in the past. Therefore, in order to prevent insufficient risk assessment, review the criteria for cases in the change control flow of the “Change Control Rules”.

- (2) Create a system to securely conduct risk assessment of emergency shutdowns in cases where highly hazardous substances are handled

One factor behind this accident is the fact that the risks during emergency shutdown could not be extracted and corrected. It is important to review all related rules as well as the risk assessment method.

[2] Insufficient passing down of skills

- (1) Improve the passing down of skills putting into consideration the emergency shutdown safety philosophy and operation results

At the resorcinol plant, the safety design of the emergency shutdown for highly hazardous reactions were not sufficiently reflected in the manuals and equipment. Therefore, at each plant, the safety design of the emergency shutdown shall be confirmed and reflected in the manuals and equipment and the operators shall be trained to ensure that the safety philosophy is being passed down. Additionally, the emergency shutdown risk inspection methods shall be reviewed based on the operation results.

- (2) Ensure that information regarding safety is communicated when there is a change in manager

On factor behind this accident was that the management was not sufficiently aware of the weaknesses in plant safety and lacked proper response to emergency shutdowns. For this reason, the “Guidelines for creating and using the Manager Safety Master File” (Production Department Guidelines) shall be used properly.

- (3) Review important emergency shutdown training relating to safety

With this accident, an operation that was not prescribed for emergency shutdown was conducted because the operator determined that the results of the emergency shutdown operation did not meet expectations. Therefore, the training details shall be revised to ensure that the emergency shutdown operation is conducted securely.

- (4) Train engineers

Training engineers is important to ensure that skills are passed down in the long term. Therefore, the existing human resource training policies shall be securely implemented.

Specific efforts to improve motivation and abilities are listed in 4. (3) “Improve technical skills of engineering staff”.

[3] Disregarding regulations and rules

(1) Ensure rules are followed when releasing interlock

In this accident, the interlock was released without implementing the prescribed procedures. Therefore, operators will be educated regarding the importance of interlock and the proper procedures will be enforced in the workplace.

(2) Review the conditions in which the interlock can be released after emergency shutdown and notify operators

The reason the interlock was released was because the operator thought the results of the emergency shutdown were not what they were supposed to be. Therefore in the future, the “stable condition” in which the interlock can be released shall be made clear, and operators shall be trained to use the checklist properly and obtain authorization from their superiors and these points shall be enforced in the workplace.

[4] Decline in onsite safety management capabilities

(1) Difference in the understanding of the reality of “Safety is our top priority” between employee grade levels

When a company conducts its production activities, the most important thing is safety. Therefore the following items shall be considered and implemented.

- Reinforce the message with “Safety is our top priority” declaration by the General Manager of the Works
- Hold effective dialogue between the Works management and onsite sections
- Utilize the various meetings as an opportunity for bilateral communication
- Periodically hold training with management and onsite sections and hearings with onsite staff

(2) Improve knowledge and awareness of explosions and fires

It was discovered through the investigation that operators did not have sufficient knowledge of the substances they handle and the processes, and there was a lack of effort to utilize the case examples of accidents that occurred in the past. Therefore the following items shall be considered and implemented.

- Prepare training material regarding risks of explosion and fire for substances and processes and safety design philosophy and conduct training
- Implement “Learning from Past Accidents”
- Raise the level of workplace process safety and disaster prevention by using specialists in process safety and disaster prevention technology

(3) Improve technical skills of engineering staff

It was discovered through this investigation that opportunities for engineering staff to experience technical deliberations for large-scale operations such as new constructions and expansions have been declining and that the training policy for engineering staff is not clear. Therefore, it is necessary to improve engineering staff training and onsite technical capabilities as well as strengthening weaknesses in equipment and the following items shall be considered and implemented.

- Confirm the technical skills of engineering staff and establish a training policy
- Hold informal meetings for engineering staff from both within the Works and outside

[5] Insufficient ownership regarding safety/hazards

(1) Enforce safety activities and follow-up

It was discovered through this investigation that safety activities were being continued without sufficient assessment, operators were feeling as though they were only doing the safety activities because they were told to and the items pointed out by the management system audits were just a formality and lacked deeper investigation into the true nature of the activities. In the future, the following items shall be considered and implemented.

- Establish an safety and environment annual plan and Works Training Annual Plan covering the priority items

- Follow-up on safety and investigation activities conducted at each worksite and provide feedback of evaluation results
- Improve the problem extraction system by creating an organization solely for internal audits

(2) Promote improvements in the workplace by the line manager

The most important measure to cultivating safety culture in the workplace is for line managers to understand the weaknesses in the climate and culture of their own workplaces and the weaknesses of the processes and equipment and to make improvements. In this investigation, it was discovered that the role of the chief during emergency shutdown was not made clear and the efforts in safety activities lacked substance. Therefore, in the future, the following items shall be considered and implemented.

- Promote improvements in workplace communication by line managers
- Start up new MKI activity program (raise morale, motivation, streamline operations and create rules to ensure operators can work comfortably)
- Deliberations to improve line operations by the Fundamental Safety Committee (Review load placed on section managers and chiefs and reorganize division of roles)

(3) Raise sensitivity towards hazards

In this investigation, regarding the lack of sensitivity towards hazards, it was discovered that there was a decline in alertness and efforts to increase sensitivity were not sufficient. Therefore, in the future, the following items shall be considered and implemented.

- Measures to prevent the decline in alertness
(Safety Day campaign, installation of a monument, utilization of eLearning, creation and utilization of disaster prevention calendar)
- Revitalize hazard prediction activities further to get operators to think for themselves
(Hazard prediction for non-routine work, process hazard prediction)

6-3. Efforts to further strengthen safety

This committee confirmed that Mitsui Chemicals will conduct the following activities.

6-3-1. Safety Reconstruction Project

(1) Project structure

The “Iwakuni-Ohtake Works Safety Reconstruction Project Team” was formed with the General Manager of the Works as the leader, and the team had begun efforts to make improvements with the participation of people from each employee level from all areas of the Works. The department in charge at the Product and Technology Center at the head office and various specialists also participate in the project as support members.

(2) The Process

In this project, specific plans regarding measures to prevent recurrence for underlying causes of the accident are drawn up and implemented. Additionally, the progress is confirmed periodically, and PDCA is implemented securely.

Figure 6-2 shows a flow chart of the process.

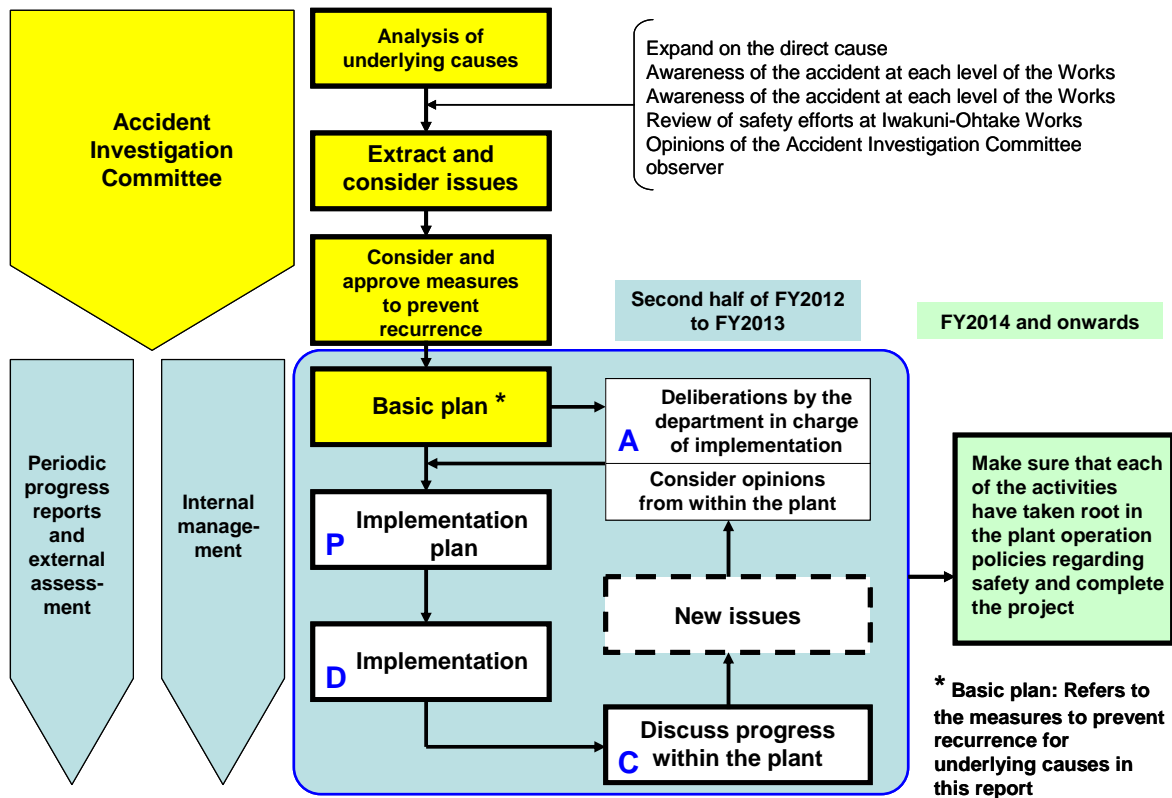

Figure 6-2 Safety Reconstruction Project

6-3-2. Strengthen dialogue between the Head Office and each Works

As we disseminate information regarding the measures to prevent recurrence for underlying causes of this accident to each Works, the cooperation between the Head Office and the Works will become increasingly important. The Head Office will place an emphasis on dialogue with the Works in various settings and support each Works in developing measures to prevent recurrence that fit the needs of the Works. Regarding the dissemination of information on measures in response to underlying causes relating to organization and workplace climate, the executives in charge from the Production and Technology Center shall hold deliberations directly with the employees of the Works, prompt discussions within the Works and work to raise the feeling of ownership among the employees regarding safety and hazards. In the future, in cooperation with the activities of the Fundamental Safety Committee, the related divisions at the Head Office and employees of the Works shall hold discussions regarding underlying causes related to organization and workplace climate in order to securely implement dissemination of information to each Works.

6-3-3. Establish a Fundamental Safety Committee and implement measures

The related divisions at the Head Office of Mitsui Chemicals and each of the Works implemented various safety activities such as improving the safety infrastructure, conducting various activities to improve organization and culture relating to safety, continuous safety investments, strengthening of production onsite capabilities, expanding a process safety management system and establishing a Plant Operation Technology Training Center in a effort to raise the safety level.

However, in response to this tragic accident, they formed the “Fundamental Safety Committee” with their President as the chairperson. Through this company-wide team with external specialists among its members, they will investigate the root causes hidden in the people, organization, technology and culture of the Works, and propose and implement measures to strengthen the foundation of safety.

The specific details of the activities are to discover issues by re-inspecting the current situation regarding people, organization, technology, and culture from the viewpoint of the worksite, through hearings and surveys of each employee level and workplace at all of the Works. It is expected that issues regarding underlying causes of this accident relating to organization and workplace climate will also be extracted through these activities. The committee will propose measures by the end of FY2012.

7. Suggestions from the Committee Chairperson

The explosion and fire we investigated was a serious one that resulted in the death of an employee and caused significant damage to the local communities. Through the investigation conducted by this committee, we were able to determine the direct cause and underlying causes of the accident. Additionally, the measures to prevent recurrence proposed by Mitsui Chemicals for the direct and underlying causes were appropriate and by properly implementing them in the future, it is our hope that they will rebuild a safe and stable plant.

In the future, we ask that Mitsui Chemicals periodically report on their progress with measures to prevent recurrence to relevant people outside the company, and securely implement these measures.

Mitsui Chemicals is one of our country's leading diversified chemical companies, and though they were confident that their independent process safety management system was being maintained, this tragic accident occurred. The accident occurred because there was a problem with the effective implementation of the requirements of the management system. These were issues that the Works and the company had regarding safety that were uncovered through the investigation of the direct causes and the analysis of the underlying causes.

It is important to remember that even if there are weaknesses in safety, if the supplementary functions are effective, accidents can be prevented. Accidents occur when we are overconfident and believe that everything is operating safely, and there is a change in situation where the supplementary functions are no longer effective. It is important to find the weaknesses in safety and implement measures, but the situation is constantly changing, so it is equally important that we build a system where we are constantly and steadily implementing measures to correct the weaknesses and confirm the effectiveness of the measures.

The issues discovered in this investigation, especially those uncovered through the analysis of the underlying causes, apply not only to the resorcinol plant but also to other Works and departments, both inside and outside of the company.

We hope that this report will prove useful to companies with similar processes and also to companies that operate and manage many production facilities and the information can be used to help prevent similar accidents in the future.

Terushige Ogawa
Chairperson
Resorcinol Plant Accident Investigation Committee
Iwakuni-Ohtake Works
Mitsui Chemicals, Inc.